

Plumber (General)

(Job Role)

Qualification Pack: Ref. Id. PSC/Q0104

Sector: Plumbing

Textbook for Class X



171020

विद्यया ऽ मृतमश्नुते



एन सी ई आर टी
NCERT

राष्ट्रीय शैक्षिक अनुसंधान और प्रशिक्षण परिषद्
NATIONAL COUNCIL OF EDUCATIONAL RESEARCH AND TRAINING

ISBN 978-93-5292-222-2

First Edition

March 2020 Phalgun 1941

PD 5T SU

© **National Council of Educational
Research and Training, 2020**

₹ 75.00

*Printed on 80 GSM paper with NCERT
watermark*

Published at the Publication Division
by the Secretary, National Council of
Educational Research and Training,
Sri Aurobindo Marg, New Delhi 110 016
and printed at Pushpak Press Private
Limited, B-3/1, Okhla Industrial Area,
Phase-II, New Delhi – 110 020

ALL RIGHTS RESERVED

- ❑ No part of this publication may be reproduced, stored in a retrieval system or transmitted, in any form or by any means, electronic, mechanical, photocopying, recording or otherwise without the prior permission of the publisher.
- ❑ This book is sold subject to the condition that it shall not, by way of trade, be lent, re-sold, hired out or otherwise disposed off without the publisher's consent, in any form of binding or cover other than that in which it is published.
- ❑ The correct price of this publication is the price printed on this page. Any revised price indicated by a rubber stamp or by a sticker or by any other means is incorrect and should be unacceptable.

OFFICES OF THE PUBLICATION

DIVISION, NCERT

NCERT Campus
Sri Aurobindo Marg
New Delhi 110 016 Phone : 011-26562708

108, 100 Feet Road
Hosdakere Halli Extension
Banashankari III Stage
Bengaluru 560 085 Phone : 080-26725740

Navjivan Trust Building
P.O.Navjivan
Ahmedabad 380 014 Phone : 079-27541446

CWC Campus
Opp. Dhankal Bus Stop
Panihati
Kolkata 700 114 Phone : 033-25530454

CWC Complex
Maligaon
Guwahati 781 021 Phone : 0361-2674869

Publication Team

Head, Publication Division : *Anup Kumar Rajput*

Chief Editor : *Shveta Uppal*

Chief Production Officer : *Arun Chitkara*

Chief Business Manager (Incharge) : *Vipin Dewan*

Production Assistant : *Rajesh Pippal*

Cover and Layout

DTP Cell, Publication Division

FOREWORD

The National Curriculum Framework–2005 (NCF–2005) recommends bringing work and education into the domain of the curricular, infusing it in all areas of learning while giving it an identity of its own at relevant stages. It explains that work transforms knowledge into experience and generates important personal and social values such as self-reliance, creativity and cooperation. Through work one learns to find one’s place in the society. It is an educational activity with an inherent potential for inclusion. Therefore, an experience of involvement in productive work in an educational setting will make one appreciate the worth of social life and what is valued and appreciated in society. Work involves interaction with material or other people (mostly both), thus creating a deeper comprehension and increased practical knowledge of natural substances and social relationships.

Through work and education, school knowledge can be easily linked to learners’ life outside the school. This also makes a departure from the legacy of bookish learning and bridges the gap between the school, home, community and the workplace. The NCF–2005 also emphasises on Vocational Education and Training (VET) for all those children who wish to acquire additional skills and/or seek livelihood through vocational education after either discontinuing or completing their school education. VET is expected to provide a ‘preferred and dignified’ choice rather than a terminal or ‘last-resort’ option.

As a follow-up of this, NCERT has attempted to infuse work across the subject areas and also contributed in the development of the National Skill Qualification Framework (NSQF) for the country, which was notified on 27 December 2013. It is a quality assurance framework that organises all qualifications according to levels of knowledge, skills and attitude. These levels, graded from one to ten, are defined in terms of learning outcomes, which the learner must possess regardless of whether they are obtained through formal, non-formal or informal learning. The NSQF sets common principles and guidelines for a nationally recognised qualification system covering Schools, Vocational Education and Training Institutions, Technical Education Institutions, Colleges and Universities.

It is under this backdrop that Pandit Sunderlal Sharma Central Institute of Vocational Education (PSSCIVE), Bhopal, a constituent of NCERT has developed learning outcomes based modular curricula for the vocational subjects from Classes IX to XII. This has been developed under the

Centrally Sponsored Scheme of Vocationalisation of Secondary and Higher Secondary Education of the Ministry of Human Resource Development.

This textbook has been developed as per the learning outcomes based curriculum, keeping in view the National Occupational Standards (NOS) for the job role and to promote experiential learning related to the vocation. This will enable the students to acquire necessary skills, knowledge and attitude.

I acknowledge the contribution of the development team, reviewers and all the institutions and organisations, which have supported in the development of this textbook.

NCERT would welcome suggestions from students, teachers and parents, which would help us to further improve the quality of the material in subsequent editions.

New Delhi
June 2018

HRUSHIKESH SENAPATY
Director

National Council of Educational
Research and Training

ABOUT THE TEXTBOOK

Plumber (General) is an important job role in the installation and repair of plumbing fittings and fixtures in 'contractors' segment. This module aims to equip the student with the skills for installation, repair maintenance and servicing of pipes and sanitary fixtures in housing, commercial and institutional setups. A Plumber (General) should be able to work independently on the assignment, and be comfortable in performing laborious work, should be a good listener, good at talking and following instructions, a good team player, result oriented with a positive attitude. After completing this module of Plumber (General), the student will be able to

- understand and use the term plumbing.
- identify power tools used in plumbing and sanitary fixtures.
- install basic plumbing and their maintenance.
- repair construction of basic plumbing.

On completion of this course, a student can take up a higher level course for a job role in the plumbing sector at the diploma and degree level. The textbook for the job role of Plumber (General) has been developed to impart knowledge and skills through hands-on learning experience, which forms a part of experimental learning. Experimental learning focusses on the learning process for the individual; therefore, the learning activities are student-centred rather than teacher-centred.

The textbook has been developed with the contribution of the subject experts, vocational teachers, industry experts and academicians, for making it a useful and inspiring teaching-learning resource material for the vocational students. Adequate care has been taken to align the contents of the textbook with the National Occupational Standards (NOS) for the job role so that the students acquire the necessary knowledge and skills as per the performance criteria mentioned in the respective NOS of the Qualification Pack (QP) PSC/Q0104.

1. PSC/N 0101: Installation of basic sanitary fixtures, fittings, related piping and accessories

2. PSC/N 0102: Repair of basic plumbing systems
3. PSC/N 0115: Installation and repair of advanced sanitary fixtures
4. PSC/N 0108: Coordinating with the seniors and other working team
5. PSC/N 0109: Maintain a healthy, safe and secure working environment

In this textbook, Unit 1 gives an introduction to plumbing operations like cutting, joining, fixing, threading and testing of pipelines. Unit 2 focusses on the plumbing and sanitary fixtures tools used in plumbing. Unit 3 deals with the basic building construction. Unit 4 discusses pumps and their installation. Unit 5 deals with the repairing of plumbing systems. Unit 6 discusses about maintaining a healthy, safe and secure work environment.

This textbook could not have been completed without the support of the Indian Plumbing Skill Council (IPSC), New Delhi. NCERT would like to acknowledge and thank IPSC for giving us the permission to use the pictures in this textbook.

We extend our gratitude to all the contributors for selflessly sharing their precious knowledge, acclaimed expertise and valuable time, and positively responding to our request for development of the textbook.

SAURABH PRAKASH
Professor

Department of Engineering and Technology
PSSCIVE, Bhopal

TEXTBOOK DEVELOPMENT TEAM

MEMBERS

Abhay Kumar Jha, *Associate Professor*, Department of Civil Engineering, Laxmi Narain College of Technology and Science, Bhopal, Madhya Pradesh India.

Avinash Singh, *Former Consultant*, Department of Engineering and Technology, Pandit Sunderlal Sharma Central Institute of Vocational Education (PSSCIVE), Bhopal, Madhya Pradesh, India

Gunjan Aneja, *Operations Manager*, Indian Plumbing Skill Council, Okhla Industrial Area, Phase-I, New Delhi, India

Hemant Wadikar, *Lecturer*, Swami Vivekanand Junior College (HSC Vocational), Sindhi Society, Chembur, Mumbai, India

Pooja Sharma, *Vice President*, Indian Plumbing Skill Council, New Delhi, India

Tapas Singh, *Assistant Professor*, Civil Engineering Department, Technocrat Institute of Technology, Bhopal, Madhya Pradesh, India

MEMBER-COORDINATOR

Saurabh Prakash, *Professor*, Department of Engineering and Technology, PSSCIVE, Bhopal, Madhya Pradesh, India

ACKNOWLEDGEMENTS

The National Council of Educational Research and Training (NCERT) expresses its gratitude to the members of the Project Approval Board (PAB) and the officials of the Ministry of Human Resource Development (MHRD), Government of India, for the financial support to the project for development of learning outcome based curricula. The Council acknowledges the contribution of the members of the Review Committee for sharing their expertise and time.

The Council would also like to thank Rajesh Khambayat, *Joint Director*, PSS Central Institute of Vocational Education (PSSCIVE), Bhopal, for providing support and guidance in the development of this textbook.

The Council is also grateful to Saroj Yadav, *Professor and Dean (Academics)*, and Ranjana Arora, *Professor and Head*, Department of Curriculum Studies, NCERT, for their sincere efforts in coordinating the review workshops for the finalisation of this book. This textbook would not have been possible without the support of the Indian Plumbing Skill Council (IPSC), New Delhi. We would like to acknowledge and thank IPSC for giving us the permission to use the pictures in this textbook. We extend our gratitude to all the contributors for selflessly sharing their precious knowledge, acclaimed expertise and valuable time, and positively responding to our request for development of the textbook. The contribution of Kuber Singh, *Junior Project Fellow*, Avinash Singh, *Consultant*, Akhilesh Kashiv, *Computer Operator*, Vikas Kumar Kogey, *Graphic Artist (Contractual)* and Pinki Tiwari, *Graphic Designer (Contractual)*, Department of Engineering and Technology, PSSCIVE, Bhopal is also acknowledged.

Gratitude is also due to the Publication Division, NCERT, for transforming the manuscript into an attractive book. Special thanks are due to Garima Syal, *Editorial Assistant*, (Contractual), and Shilpa Mohan, *Assistant Editor (Contractual)*, Publication Division, NCERT. The efforts of Pawan Kumar Barriar, *DTP Operator*, and Hari Darshan Lodhi, *DTP Operator (Contractual)*, Publication Division, NCERT, for flawless layout design are also acknowledged.

CONTENTS

<i>Foreword</i>	<i>iii</i>
<i>About the Textbook</i>	<i>v</i>
Unit 1: Pipes – Cutting, Threading, Joining and Testing of Pipelines	1
Unit 2: Plumbing and Sanitary Fixtures	12
Unit 3: Basic Building Construction	22
Unit 4: Pumps and their Installation	31
Unit 5: Performing various Plumbing related Operations and Procedures	39
Unit 6: Maintaining a Healthy, Safe and Secure Work Environment	56
<i>Glossary</i>	<i>73</i>
<i>Answer Key</i>	<i>74</i>

© NCEPT
not to be republished

Do You Know

According to the 86th Constitutional Amendment Act, 2002, free and compulsory education for all children in 6-14 year age group is now a Fundamental Right under Article 21-A of the Constitution.

EDUCATION IS NEITHER A PRIVILEGE NOR FAVOUR BUT A BASIC HUMAN RIGHT TO WHICH ALL GIRLS AND WOMEN ARE ENTITLED

*Give Girls
Their Chance !*



Unit



Pipes - Cutting, Threading, Joining and Testing of Pipelines

INTRODUCTION

In Class IX, you have studied important tools used for plumbing, plumbing materials, plumbing pipes, measurement and symbols used in plumbing as well as pipe fittings, joints and valves. In this textbook, we will be discussing related features of plumbing.

For successful installation, fixing and testing, various types of operations are carried out. These are cutting, threading, joining and testing.



171020CH01

CUTTING

Pipe is one of the important materials in plumbing work. As per requirement, a pipe is cut into different sizes. A pipe is cut manually or with a machine. The length of a pipe to be cut should be marked on the pipe with a pencil.

Common tools used for pipe cutting are as given below.

- (a) Plastic tubing cutters
- (b) Wheel cutters
- (c) Hacksaws



Fig. 1.1: Plastic cutter

- **Plastic tubing cutters** are used for thinner pipes and tubes, such as a sprinkler pipe.
- **Wheel cutters**, with a sharp wheel are used for thicker pipes. It has an adjustable jaw grip. It is used in areas where a complete turn is not possible. A wheel cutter is used by rotating it around the pipe and repeatedly tightening it until it cuts all the way through. During the cutting process, a small burr is left in the pipe, which creates hurdles. The burr should be cleaned or reamed.

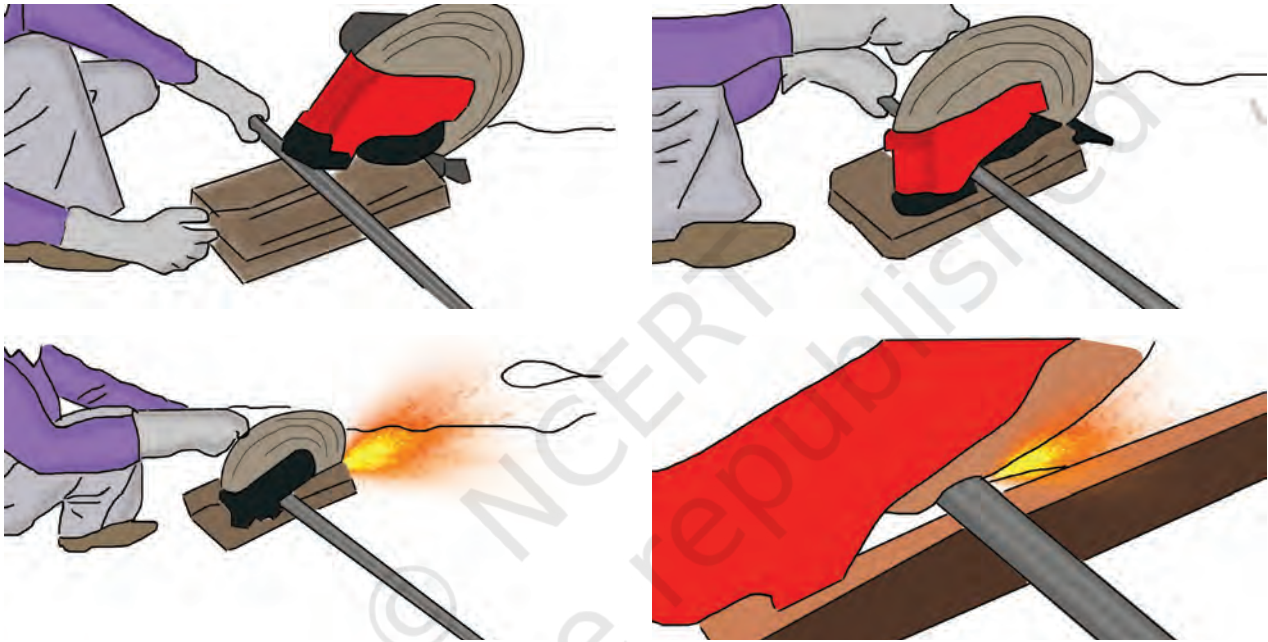

Fig.1.2: Wheel cutter

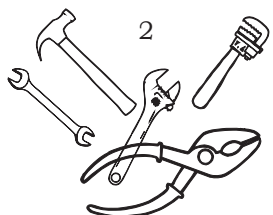

Fig.1.3: Cutting with a hacksaw

- **Hacksaws** are used for cutting metal and plastic pipes. A hacksaw should be held properly when cutting a pipe. The blade of the hacksaw should be changed when it becomes blunt.

THREADING

You already know that during installation of plumbing pipes and fixtures, joining is done with the help of screws and threads. The purpose of threading is to create a screw thread. Threading is done with a tap or faucet and dies. Tap or faucet and dies are cutting tools used to create screw threads.



- (a) A tap or faucet is used to cut the internal portion of the bolt (for example, a nut).
- (b) A die is used to cut the external portion of the bolt (for example, a screw).
- (c) The process of cutting threads using a tap or faucet is called tapping/fauceting, whereas the process of using a die is called threading.
- (d) Both the tools can be used to clean up a thread, which is called chasing.
- (e) A tap or faucet cuts a thread on the inside surface of a hole, creating a surface, which functions like a nut.
- (f) The die cuts a thread on a preformed cylindrical rod, which creates a threaded piece that functions like a bolt.
- (g) Unlike drill bits, hand tap or faucets do not automatically remove the chips they create.

Thread Cutting

Thread cutting is used when a full thread depth is required, the quantity is small and the blank is not accurate. A common method of threading is cutting with taps and dies. A hand tap cannot cut its threads in a single rotation because it creates long chips, which quickly jam the tap.

In manual thread cutting, normal wrench usage is to cut the threads $\frac{1}{2}$ to $\frac{2}{3}$ of a turn (180 to 240 degree rotation), then reverse the tap for about $\frac{1}{6}$ of a turn (60 degrees) until the chips are broken by the back edges of the cutter. A threaded pipe is a pipe with screw-threaded ends for assembly. Threaded pipes used in some plumbing installations for the delivery of gases or liquids under pressure, have a tapered thread that is slightly conical.

Determine the Threads per Inch

Tapping is done when the threads are cut into a hole. A die set is used to cut threads onto a cylinder (bolt). To use a tap or a die, first determine the number of threads per inch (TPI) of the part to be fixed. A gauge system that has a number of different pins can be used



Fig. 1.4: Measuring the thread per inch

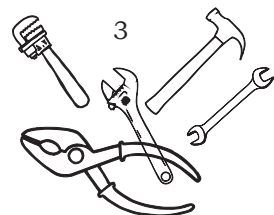



Fig.1.5: Creating a thread



Fig. 1.6. Turning steel rod into a bolt

to calculate the TPI of a bolt or nut. After determining the TPI of a bolt, choose the die that corresponds to it. A tapered die will tell which side to begin using. The die fits into a special wrench that holds and guides it.

Create New Threads

To use the die to create new threads on a worn out bolt, first place the bolt into a vise to hold it as the wrench is turned over it. Cutting metal with metal can create heat, so some cutting oil is used to lubricate the bolt. Place the die over the bolt and hold it horizontally. Turn the wrench. The die will catch the threads already cut into the bolt. Every couple of turns, reverse the wrench about half a turn to clear the threads so that the die cuts better. Also, re-apply cutting oil throughout the process. Turn the wrench until the bolt comes past the top of the die.



Fig.1.7: Tap and Die

Turn a Steel Rod into a Bolt

A die set can also be used to turn an ordinary steel rod into a bolt. To do this, the rod must have a beveled end. If necessary, chamfer the end of a rod on a grinder to get a bevel. The die will not work well with a flat-ended rod. Lubricate the rod often, as when cutting into a worn bolt. Make turns slowly.



Fig.1.8: Pipe threading using pipe threading machine

To use a tap, choose a size that is appropriate for the size of the bolt or the hole you want to thread. Place the tap into the special wrench and tighten it. Then, place

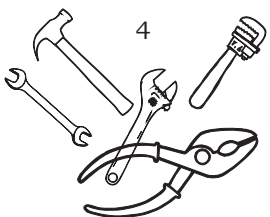

the cutting end of the tap over the hole and turn. Use cutting oil to lubricate the tap. As with the die, once the tap starts, make a slight reverse turn every now and then.

Pipe Threading Machine

This machine is used for making thread in a pipe. The pipe is fixed in the jaws of the machine. As per the pitch of the thread, the setting is made in the die. It is rotated slowly and the thread is created.

A pipe threader is used to cut grooves or threads in to the end of a metal pipe. These grooves are similar to those found on a conventional screw. The threads on the pipe fit into a pattern of threads in the connector, allowing users to screw the two components together by hand. Before threading the pipe, plumbers use a pipe-cutting tool to cut the pipe to the desired length. The end of the pipe is then inserted into the pipe threader. Special cutting tools or dies, within the threader can be used to create the proper thread profile and depth.



Fig.1. 9: Pipe Threader

Process of Threading a Pipe

Before starting the threading process, all the tools to be used should be stored properly. Proper care should be taken during the process. The steps of threading are explained in Table 1.1.

Table 1.1: Steps of Threading a Pipe

<p>Check and inspect the pipe threader before beginning. Worn out or damaged dies can result in poor thread quality.</p>	
<p>Mount your pipe firmly in the pipe vice tightly.</p>	

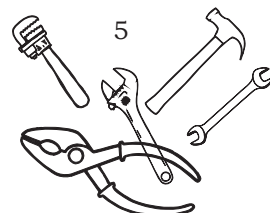

<p>Cut the end of the pipe smoothly and squarely by using a pipe cutter.</p>	
<p>Ream the cut end of the pipe to remove any burrs from the cut using a reamer. It is a cylindrical rotary cutting tool that you run smoothly across the freshly cut edges of the pipe to remove rough edges.</p>	
<p>Select your die head according to the size and type of pipe you are threading and the thread form you require. Die heads come in different shapes and sizes that include different threads for pipes that have different diameters.</p>	
<p>Place the die head over the pipe on the threader.</p>	
<p>Press steadily on the front of the die head, while simultaneously pushing the handle down to start the threader. Before putting too much pressure on the handle, check to be sure the ratchet pawl is engaged.</p>	
<p>Use your weight as leverage to apply pressure on the handle, while holding it firmly. Be sure to maintain a proper footing and balance for maximum control. Otherwise, this can be dangerous and could result in an injury.</p>	

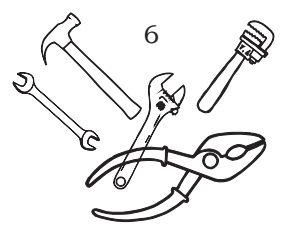

Reverse the ratchet mechanism and turn the die head in the opposite direction. Be careful to maintain control of the threader and move the piece smoothly as the dies are removed and the threads can get damaged.

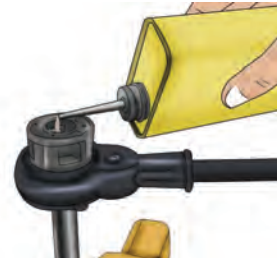

Clean the pipe with a cloth, removing oil if any. Be careful as the threads are sharp. Seal the threading with Teflon tape or faucet or a pipe thread compound when attaching the pipe to the connector.

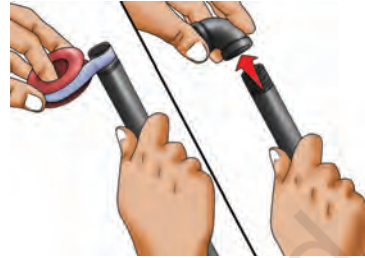

JOINING OF PVC PIPES

Joining is the method of joining non-metallic, plastic pipes. It does not require threading of ends. Chlorinated Polyvinyl Chloride (CPVC) pipes are joined using a solvent cementing technique.



CPVC Solvent Cementing

1. The following points should be clearly understood.
2. The joining surfaces must be softened and made semi fluid.
3. Sufficient cement must be applied to fill the gap between the pipe and the fitting.
4. The assembly of the pipe and fittings must be made while the surfaces are still wet and the cement is still fluid.
5. Joint strength develops as the cement dries. In the tight part of the joint the surfaces tend to fuse together. In the loose part, the cement will bond with both the surfaces. These areas must be softened and penetrated.



Fig.1.10: Cut and clean the edges of the pipe



Fig.1.11: Apply the solvent on both the edges



Fig.1.12: Assemble the edges when the cement solvent is wet

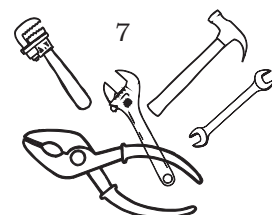

METHODS OF TESTING PIPELINES

Testing the pipeline is necessary after installation. There are four different testing methods of the pipeline, which are as follows.

Smoke Test

This test is done in the case of leakage in CI pipe.

1. Smoke is released from the bottom of the pipe.
2. Smoke can be detected from the leaked portion, if any.
3. Smoke testing refers to physical tests on closed systems of pipes to detect cracks or breaks.
4. In plumbing, a smoke test forces non-toxic, artificially created smoke through waste and drain pipes under a slight pressure to find leaks.
5. Plumes of smoke form where there are defects.
6. This test can be performed when the plumbing is brand new. More often it is used to find sewer gas leaks that may plague a building or an area.
7. Any sign of smoke escaping can be considered a possible site for sewer gas to escape. Plumbing

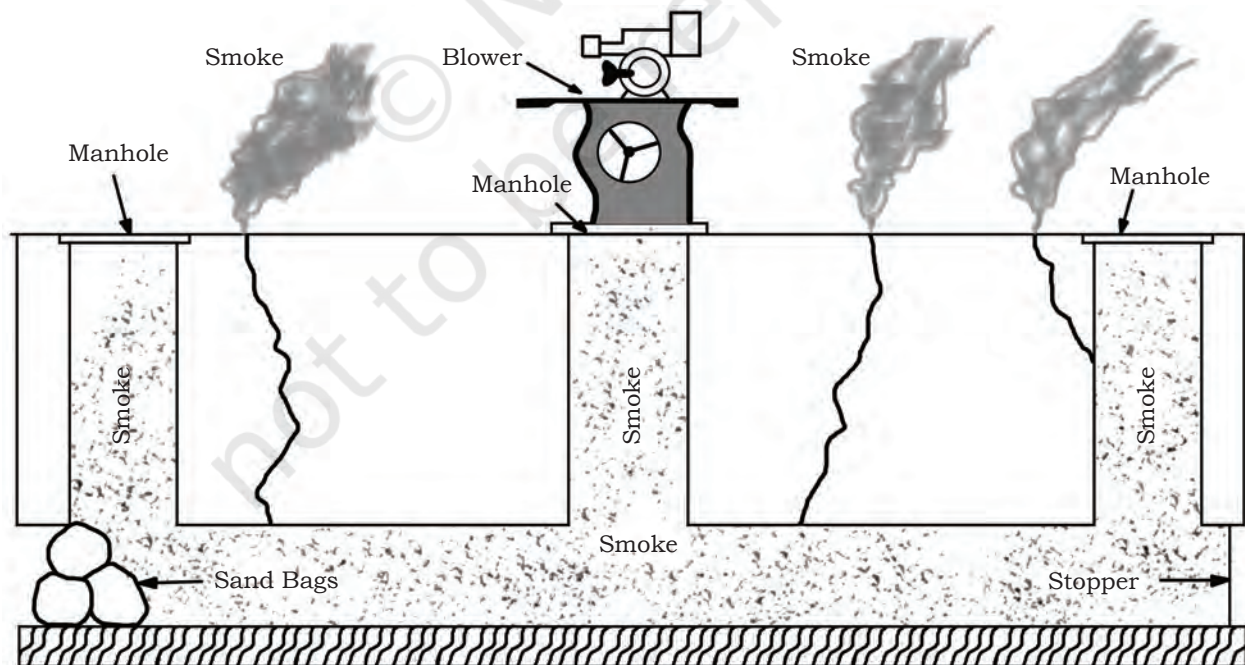
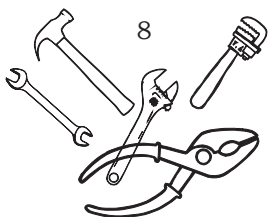

Fig.1.13: Smoke Test



smoke tests are also used to find places where pipes will spill fluid, and to check sanitary sewer systems for places where groundwater and storm runoff can enter.

Pressure Hydraulic Test

This test is also done to detect leakage in the pipes.

1. For pressure test, open the ball valve on the pressure tester and then connect a garden hose to the tester.
2. Turn the hose on and allow the pressure in the pipes to reach 30 pounds per square inch (psi). This usually takes several minutes.
3. When it reaches 30 psi on the gauge, close the ball valve on the pressure tester assembly and then turn off the hose. You can now disconnect the hose from the pressure tester assembly.
4. The pressure should stay at 30 psi.
5. Leave the hose on at this pressure for several hours to make sure you do not have a small leak.
6. If the gauge does begin to drop slowly, check the plumbing for leaking water.

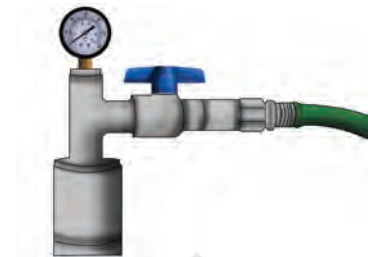

Fig.1.14: Pressure Hydraulic Test

Practical Exercises

Activity 1

Cutting of the PVC Pipe

Material required

- | | |
|-----------------|-----------------|
| 1. Cutting tool | 3. Hacksaw |
| 2. PVC pipe | 4. Wheel cutter |

Procedure

1. Select a PVC Pipe.
2. Mark with a pencil on the PVC pipe, where cutting is to be done.
3. Take a hacksaw and check whether the blade is fitted properly or not.
4. Keep the pipe on a table hold the pipe.
5. Cut the pipe with the help of hacksaw.

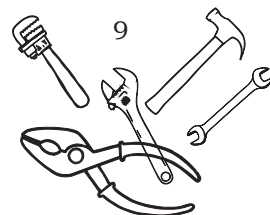

NOTES

6. Fix the pipe in the wheel cutter and slowly cut the pipe.
7. Remove the burr around and inside the PVC pipe.

Activity 2

Threading in PVC pipe

Material required

1. PVC or metal pipe
2. Taper die
3. Bench vice
4. Pencil
5. Pipe threading machine
6. Tap
7. Teflon Tape

Procedure

1. Take a pipe.
2. Fix in a bench vice.
3. Identify and collect the die.
4. Fix the die in the tap.
5. Rotate the tap and die slowly.
6. Thread will be created on the pipe.
7. Pipe threader may be used for making grooves in the metal pipe.

Instructions

1. Clean the pipe with the help of a cloth and remove any oil.
2. Seal the thread with a Teflon tape.

Activity 3

Joining of PVC pipe using adhesive

Material required

1. PVC pipe
2. Brush
3. Adhesive

Procedure

1. Clean the end of the pipes with a cloth.
2. Fit one pipe into the other without adhesive.
3. Check that both the components are matching.
4. With the help of a brush apply the adhesive solution to the end of the pipe.
5. Hold the pipe material for a few minutes.
6. The pipes will join.

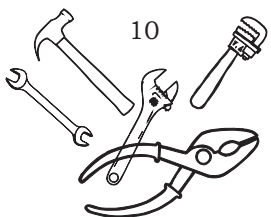

Check Your Progress

NOTES

A. Short answer questions

1. List the three cutting tools used for cutting pipes.
2. Explain how threads are made on a pipe.
3. Describe the different plumbing operations performed on a pipe.
4. How is pipe cutting done on site?

B. Multiple choice questions

1. Which of the following tools is used to cut the internal portion of the bolt?
(a) Tap
(b) Die
(c) Cutter
(d) Pipe threader
2. Chisel Threading machine is used to _____.
(a) make a hole in a pipe
(b) make a thread in a pipe
(c) make a die in a pipe
(d) None of the above
3. Which of the following methods is used for pipe cutting?
(a) Plastic tubing
(b) Wheel cutters
(c) Hacksaw
(d) All of the above
4. The process of cutting thread using a tap is called _____.
(a) tapping
(b) threading
(c) cutting
(d) bending
5. While conducting a pressure test, how much pressure should be retained in the pipes?
(a) 30psi
(b) 40psi
(c) 55psi
(d) 25psi

C. Fill in the blanks

1. Smoke is released from the _____ of the pipe_____.
2. _____ test is done in case of a leakage in CI pipe.
3. TPI stands for_____.
4. In manual thread cutting, normal wrench usage is to cut the threads _____ to _____ of a turn.

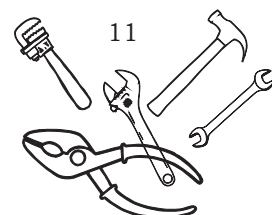

Plumber General Class 10

Unit 1: Pipes – Cutting, Threading, Joining and Testing of Pipelines

Check Your Progress

A. Short answer questions

1. List the three cutting tools used for cutting pipes.
2. Explain how threads are made on a pipe.
3. Describe the different plumbing operations performed on a pipe.
4. How is pipe cutting done on site?

B. Multiple choice questions

1. Which of the following tools is used to cut the internal portion of the bolt?
(a) Tap
(b) Die
(c) Cutter
(d) Pipe threader
2. Chisel Threading machine is used to _____.
(a) make a hole in a pipe
(b) make a thread in a pipe
(c) make a die in a pipe
(d) None of the above
3. Which of the following methods is used for pipe cutting?
(a) Plastic tubing
(b) Wheel cutters
(c) Hacksaw
(d) All of the above
4. The process of cutting thread using a tap is called _____.
(a) tapping
(b) threading
(c) cutting
(d) bending
5. While conducting a pressure test, how much pressure should be retained in the pipes?
(a) 30psi
(b) 40psi
(c) 55psi
(d) 25psi

C. Fill in the blanks

1. Smoke is released from the _____ of the pipe _____.
2. _____ test is done in case of a leakage in CI pipe.
3. TPI stands for _____.
4. In manual thread cutting, normal wrench usage is to cut the threads _____ to _____ of a turn.

Unit



Plumbing and Sanitary Fixtures



171020CH02



Fig. 2.1: Tap or Faucet



Fig.2.2: Single Lever Mixer

PLUMBING AND SANITARY FIXTURES

You must have seen plumbing and sanitary fittings and fixtures installed in the kitchen, bathroom or toilets of your home, school or other buildings. Many people confuse the words plumbing fittings and plumbing fixtures. A fixture is a part that is connected to a plumbing system and carries water through a building. The most common plumbing fixtures are bathtubs, sinks, showers, tubs, toilets and faucets. While a fixture can be fixed into walls or the floor, a fitting is an item that can be hung by a hook, screw or nail.

TAP OR FAUCET

A tap or faucet is a valve used for controlling or release of liquids or gas. These taps are available in varieties for the simple act of turning a tap or faucet on or off.

Single Lever Mixer

It is meant to control the water and temperature. A single lever handle tap or faucet is easy to grip and turn. These are available in many decorative styles.

Joystick

It is similar to a lever handle tap or faucet, yet with a different look and different range of motion.

Push Tap or Faucet

It turns the water on with a push instead of turning a handle or knob. It is used for predetermined flow of water.

Sensor Tap or Faucet

It does not require handles or knobs at all. Most automatic taps or faucets are battery powered and incorporate a passive infrared sensor to detect hand motion. Automatic taps or faucets are common in public washrooms, particularly airports and hotels, where they help reduce water consumption and transmission of disease causing microbes.

SHOWER

The modern shower comes with configurable temperature and spray pressure settings, along with adjustable showerhead nozzle settings.

WASHBASIN

A washbasin is a bowl-shaped fixture used for washing hands, dishwashing or other purposes. The most significant difference between major washbasin types is the manner in which they are installed.

Wall-mounted

A wall-mounted washbasin hangs directly from the wall, taking up little space and offering easy access to plumbing hook-ups. These are ideal options for half baths and small bathrooms.

Pedestal

A pedestal washbasin is also wall-mounted washbasin that rests on a pedestal which may or may not provide actual support to the washbasin bowl. Usually, the pedestal conceals plumbing. The drawback of this type is the lack of storage space under the bowl.



Fig.2.3: Joystick



Fig.2.4: Push Tap



Fig.2.5: Sensor Tap



Fig.2.6: Shower



Fig.2.7: Wall-mounted washbasin



Fig.2.8: Pedestal washbasin

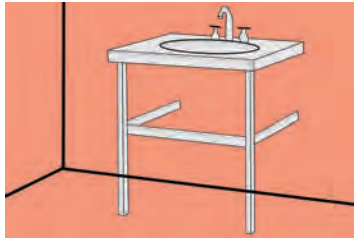

Fig. 2.9: Console washbasin

Console

A console washbasin is also wall-mounted that rests on legs. The legs support the front two corners while an apron often masks the plumbing hook-ups. A small storage space can be created underneath simply by placing a basket or a shelving unit.



Fig. 2.10: Self Rimming washbasin

Self-rimming

A self-rimming washbasin drops into a cut-out in the countertop and is usually secured with mounting clips from below. The rim overlaps the cut out edges.



Fig. 2.11: Integral washbasin

Integral

An integral washbasin is usually made of solid surface material like Corian (acrylic polymer and alumina trihydrate derived from bauxite ore) and acrylic. The bowl and the countertop are one piece and easy to clean and maintain.

STANDARD DIMENSIONS FOR INSTALLATION

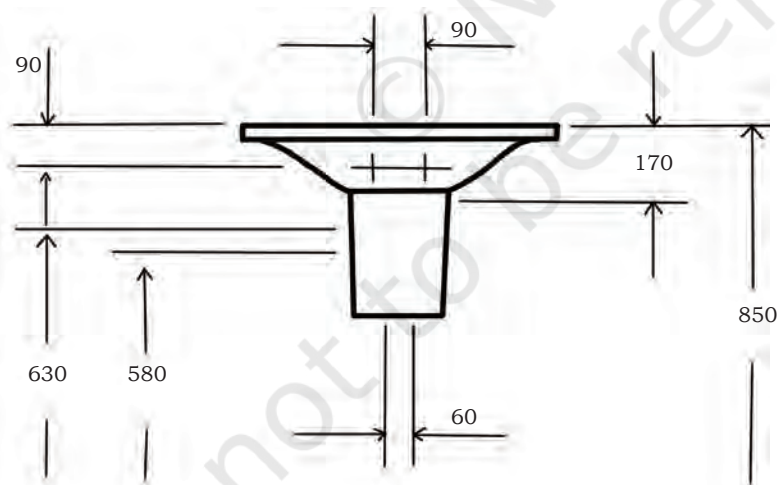
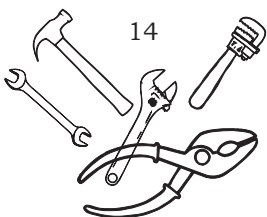

Fig.2.12: Installing a pedestal washbasin with a standard height in cms



① Side wall grab bar must be 42" wide min, and start 12" away from the rear wall.

② Toilet paper dispenser mounted not more than 36" away from the rear wall.

③ Urinal must have tapered elongated rim extending out at least 14" from the wall.

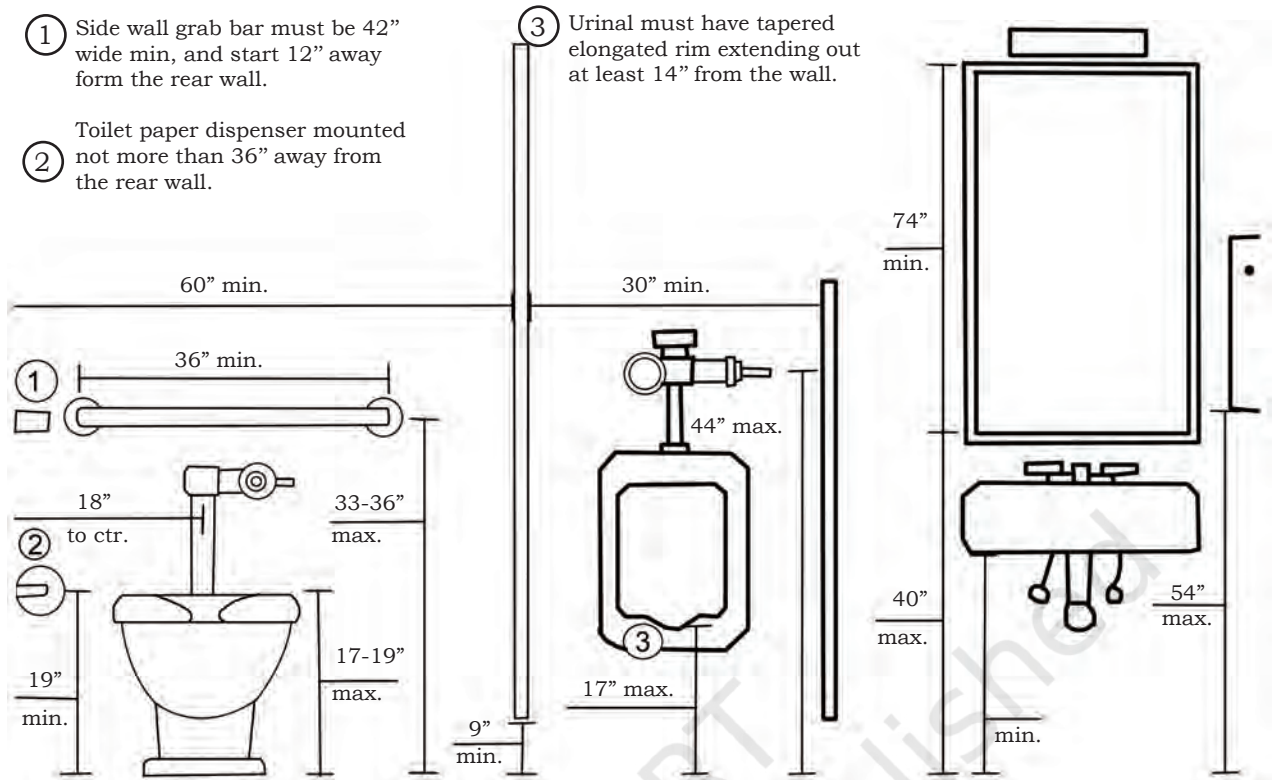

Fig. 2.13: Standard toilet room specification in inches

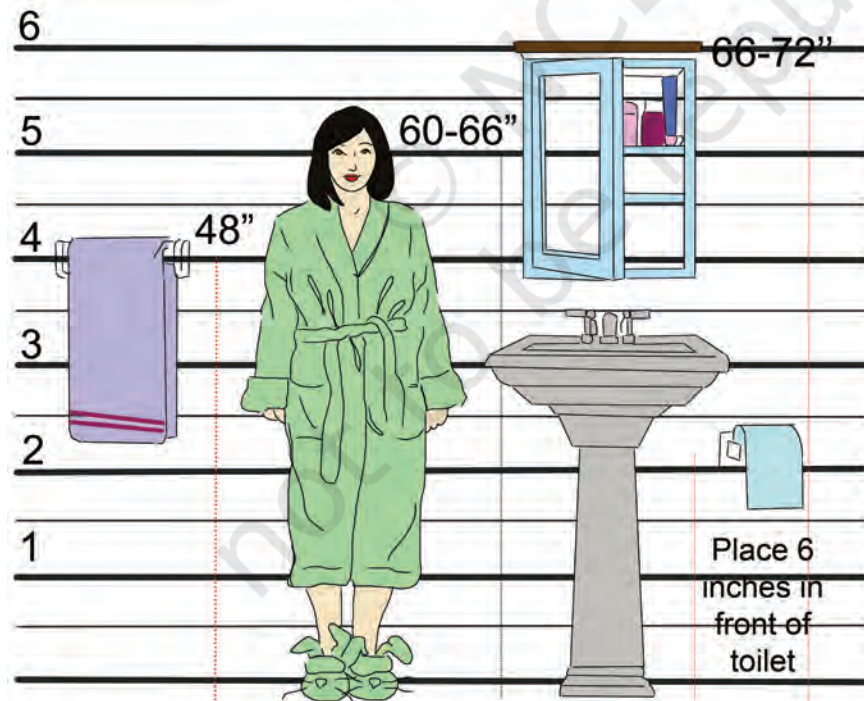
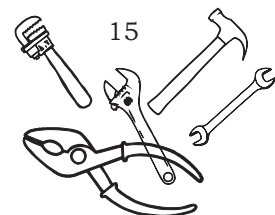

Fig.2.14: Standard height of fixtures in bathroom in inches



WATER CLOSETS

A water closet (WC) is a fixture for the toilets used to carry out human excreta.



Fig.2.15: Indian water closet

Indian

An Indian water closet is commonly used in the eastern part of the world—India, Bangladesh including, Pakistan, Sri Lanka, Nepal and Bhutan. It is shaped in a way that one has to sit on one's haunches. Its basin has an inverted slope towards the back of the closet where a trap leads to the sewer pipe (drain) from it.



Western

A western water closet is very popular and commonly used in the western part of the world. It is shaped like a chair and is used in the same manner. It is sloped from the back and connects with the drain through a trap. There are two types of western water closets—a one-piece with a basin and the trap manufactured together; and a two-piece in which, the basin and the trap are manufactured separately.



Fig.2.16: Western water closet

FLUSHING CISTERN

A flushing cistern is used for storage and discharge of water for flushing out the excreta from a WC and urinals. A flushing cistern is also known as a water waste preventer. It is used to throw water with pressure after the use of the WC and urinals.



Fig.2.17: Flushing Cistern

Flush Tank

This is a tank that holds fluid in reserve for flushing and is attached to a toilet. Today's toilets are typically a two-piece (tank and bowl) plumbing fixture made out of vitreous china. The mechanical components, which

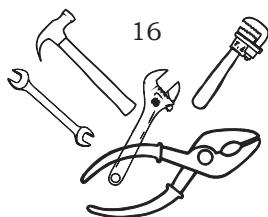

are located inside the tank, work together as a system to perform a gravity flush.

Bell Flushing Cistern

A bell flushing cistern is only suitable when installed at a height. It is made of cast iron with a capacity of 5 to 15 litres. Now virtually outdated, it may still be found in old factories, schools and similar established buildings. It consists of a bell connected to a flushing chain through a lever. When the chain is pulled, the bell is lifted and the water in the tank rushes through the flushing pipe by a siphon action. The float valve allows the water from the inlet into the cistern. Once the water starts moving down the pipe, it starts a siphon effect. The rest of the water is drawn from the cistern and the emptying action takes only a few seconds causing a powerful flush in the WC below. The chain should be released immediately after being pulled to force the water out of the flush pipe. This cistern is supplied with water through a ball valve arrangement. The water inlet closes when the cistern is full and open when it is empty, permitting entry of water. It also has an overflow pipe to drain out excess incoming water if the ballcock stops functioning to avoid overflow of water from the cistern into the toilet.

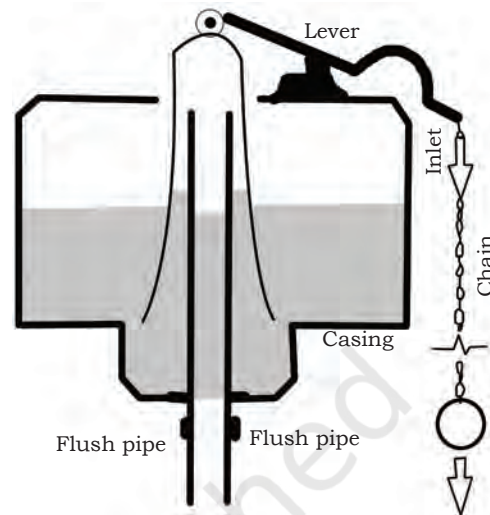

Fig.2.18: Bell Flushing Cistern

Flat-type Cistern

This type of cistern is placed at a height of 3ft above the floor, are commonly used now. It is generally made of plastic and has a flat valve inside. It stops the water after the tank gets filled and starts after the tank becomes empty. Water flushes out at the press of a button.

Automatic Cistern

This type of cistern is mainly used in urinals. A lot of water is used in these cisterns. These cisterns are mainly used in public places, for example, bus stands, railway stations, offices, etc.

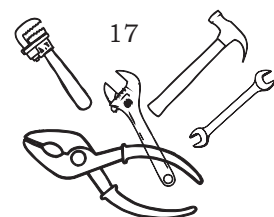

URINALS

A device, usually attached to a wall into which men or boys can urinate. Urinal flushing is done by manual handles, time flush, automatic flush, waterless urinals.

Manual Handles

Each urinal is equipped with a button or a short lever to activate the flush. Users are expected to operate it before they leave. Such a directly controlled system is the most efficient, provided the patrons remember to use it.

Timed Flush

A constant drip-feed of water slowly fills the cistern, until a tipping point is reached. The valve opens (or a siphon begins to drain the cistern), and all the urinals in the group are flushed. Electronic controllers performing the same functions are also used.

Automatic Flush

Electronic automatic flushes solve the problems of both previous approaches, and are common in new installations. Passive infrared sensors identify when the urinal has been used (or when someone has stood in front of it and moved away), and activate the flush. Thus, the urinal gets cleaned and water is not wasted when the toilet is not in use. With a manual flush it might not have been possible.

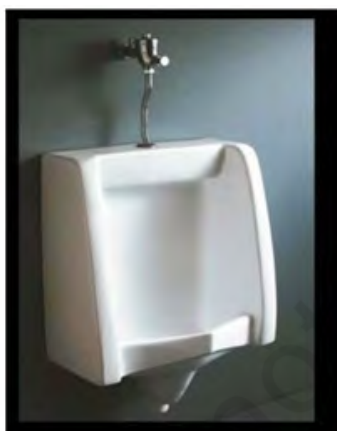

Fig.2.19: Waterless Urinals

Waterless Urinals

In this, a trap insert is filled with a sealant liquid instead of water. The lighter-than-water sealant floats on top of the urine collected in the U-bend, preventing odours from being released into the air. The cartridge and sealant must be periodically replaced.

BIDETS

Bidets are primarily used to wash and clean. They may also be used to clean any other part of the body, such

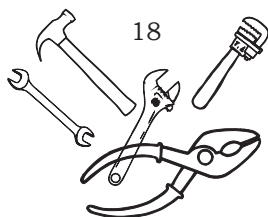

as the feet. Despite appearing similar to a toilet, it would be more accurate to compare it to the washbasin or a bathtub.

BATHTUB

Installed in a bathroom, it is made of vitreous material, enamelled iron, plastic, marble, etc. Its length varies from 1.7 m to 1.85 m, the width is 70 cm × 75 cm and the depth varies from 43 cm to 45 cm to the outlet end. Cold and hot water taps are provided for filling the tank, and an overflow pipe is provided for excess water drainage. A waste coupling with a waste seal trap is provided at the drain with a rubber plug as in the washbasin.



Fig.2.20: Bathtub

GEYSER

It is used for heating water. It is available in different capacities, up to 25 liters, as per requirement.

STANDARD HEIGHT OF SANITARY FIXTURES

Wet room installations are largely standardised and sanitaryware is supplied in a range of fixed dimensions. In the figure shown below the graphic representation shows a typical height of the most common sanitaryware. The sanitary fixtures, height are in cms.



Fig.2.21: Geyser

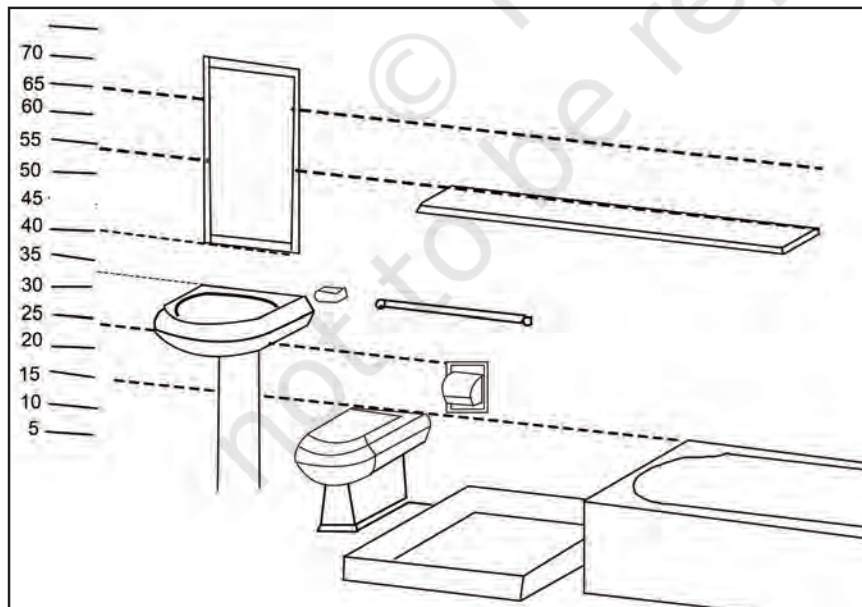
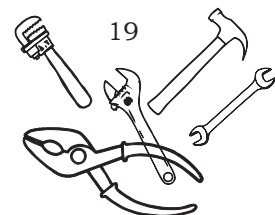

Fig.2.22: Dimensions are in inches



Practical Exercises

Activity 1

Make a list of plumbing fixtures fitted in your school

Material required

1. Drawing copy
2. Pencil

Procedure

1. Visit the school washroom.
2. Identify the different types of fixtures installed in the bathroom.
3. Note down the technical details of the fixtures in the bathroom.
4. Make a drawing for identifying the fixtures.

Activity 2

Sketch a washbasin

Material required

1. Pen
2. Drawing copy
3. Pencil

Procedure

1. Visit the bathroom at your home.
2. Identify the washbasin fitting.
3. Measure the dimensions.
4. Draw on your copy.

Activity 3

Measure the standard dimensions of installed of fixtures in the bathroom

Material required

1. Pen
2. Pencil
3. Copy

Procedure

1. Visit the bathroom at your home.
2. Identify the fitting fixtures in your bathroom.
3. Measure the dimensions with the help of a measuring tape.
4. Note down the dimensions in your notebook.
5. Discuss with the class teacher.

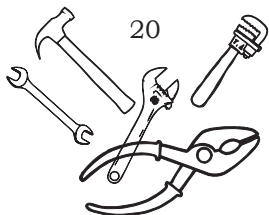

Check Your Progress

NOTES

A. Short answer questions

1. Name the various types of plumbing and sanitary fittings with neat sketches and describe any one of these.
2. Write short notes on
 - (a) Washbasin
 - (b) Bathtub
 - (c) Types of sinks used
3. Give the general principle of design of sanitary fittings.
4. What are the sanitary provisions of a house?

B. Multiple choice questions

1. Which of the following is the average fixing height for a basin?
 - (a) 28–32 inches
 - (b) 18–20 inches
 - (c) 22–25 inches
 - (d) 35–40 inches
2. A flat-type WC must be fitted at a height of _____.
 - (a) 3ft
 - (b) 2.5ft
 - (c) 1ft
 - (d) 3.75ft
3. The fixture for the toilets used to carry out human excreta is _____.
 - (a) water closet
 - (b) urinal
 - (c) tap
 - (d) faucet
4. A bell flushing cistern is made up of _____.
 - (a) cast iron
 - (b) metal
 - (c) wrought iron
 - (d) chimney

C. Fill in the blanks

1. Washbasin is a _____ fixture used for washing hands.
2. A console washbasin is also wall-mounted that rests on _____.
3. A water closet (WC) is a fixture for the _____ used to carry out human excreta.
4. Timed flush is used to provide _____ at regular intervals.
5. Geyser is used for _____ water in bathroom.

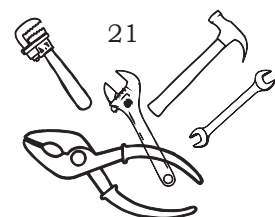

Plumber General Class 10

Unit 2: Plumbing and Sanitary Fixtures

Check Your Progress

A. Short answer questions

1. Name the various types of plumbing and sanitary fittings with neat sketches and describe any one of these.
2. Write short notes on
 - (a) Washbasin
 - (b) Bathtub
 - (c) Types of sinks used
3. Give the general principle of design of sanitary fittings.
4. What are the sanitary provisions of a house?

B. Multiple choice questions

1. Which of the following is the average fixing height for a basin?
 - (a) 28–32 inches
 - (b) 18–20 inches
 - (c) 22–25 inches
 - (d) 35–40 inches
2. A flat-type WC must be fitted at a height of _____.
 - (a) 3ft
 - (b) 2.5ft
 - (c) 1ft
 - (d) 3.75ft
3. The fixture for the toilets used to carry out human excreta is _____.
 - (a) water closet
 - (b) urinal
 - (c) tap
 - (d) faucet
4. A bell flushing cistern is made up of _____.
 - (a) cast iron
 - (b) metal
 - (c) wrought iron
 - (d) chimney

C. Fill in the blanks

1. Washbasin is a _____ fixture used for washing hands.
2. A console washbasin is also wall-mounted that rests on _____.
3. A water closet (WC) is a fixture for the _____ used to carry out human excreta.
4. Timed flush is used to provide _____ at regular intervals.
5. Geyser is used for _____ water in bathroom.

Unit



Basic Building Construction



171020CH03

INTRODUCTION

As you know, plumbing fittings and fixtures are installed at various places in the building structure. These include the bathroom, kitchen, washroom, roof, etc. As a plumber has to install these at the appropriate locations, it is important that one is aware of the names of the components of a building. This Unit will explain all the components in detail. .

Plumbing in a Building

As you know that there are various elements in a building. These elements are foundation, structure, floors and ceiling, exterior walls, windows, roof, internal wall, etc.

Figure 3.1 represents the essential elements of a modern building.



Fig.3.1: Essential elements of a modern building

Foundations: This is a structure (made, mainly, of cement, iron and coarse sand) that transfers loads to the earth. The primary design concerns are settlement and tearing capacity.

Structure: This comprises pillars, beams and tie-beams made of reinforced concrete or iron.

Floors and ceiling: Hollow tiles are placed between two tie-beams, later it is covered by a layer of concrete, floors are finished with floor tiles or floorboard.

Exteriors walls: These are usually made by two brick walls and an insulator layer.

Windows: These provide a visual link between internal space and the outside world. They are very important for the mental health of the people in the house. A small tie-beam is placed above the window to bear the load of all bricks situated over the window frame.

Roof: Its functions are to protect a building from the weather and to retain the heat generated inside. It comprises of a wood or iron structure, a thermal material, such as fiberglass and the last layer, the tiles or slates.

Internal walls: The primary function of internal wall is to divide the overall space within the house into smaller spaces. They are made of brick, wood or plaster.

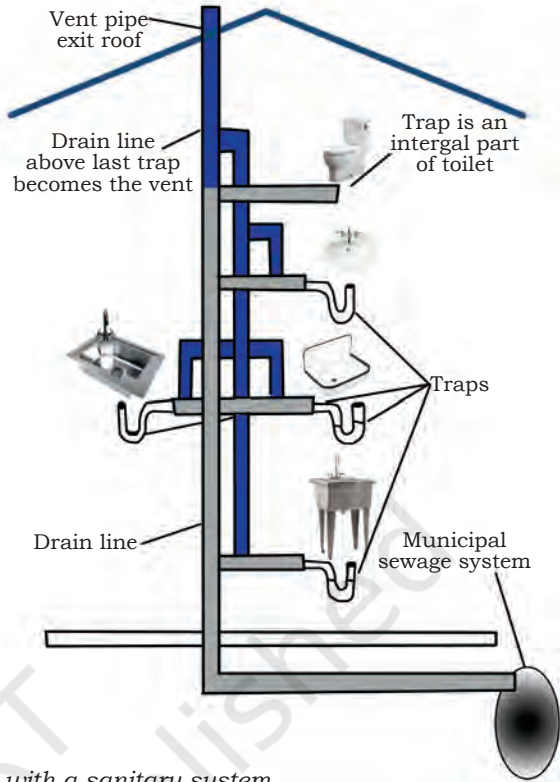
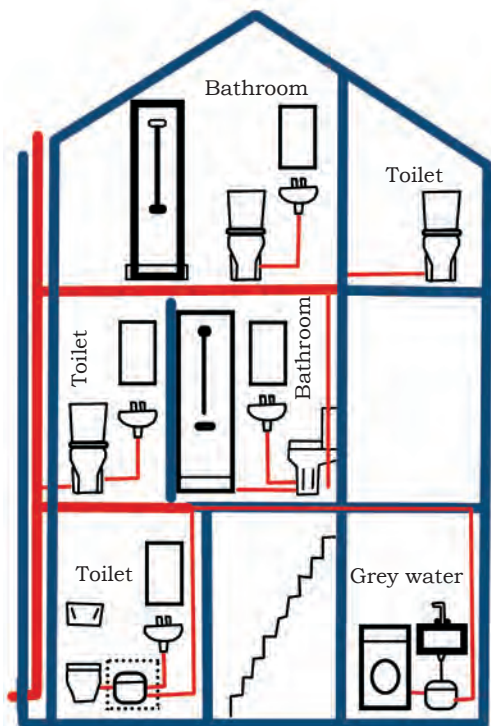

Fig.3.2: Sectional view of a building with a sanitary system

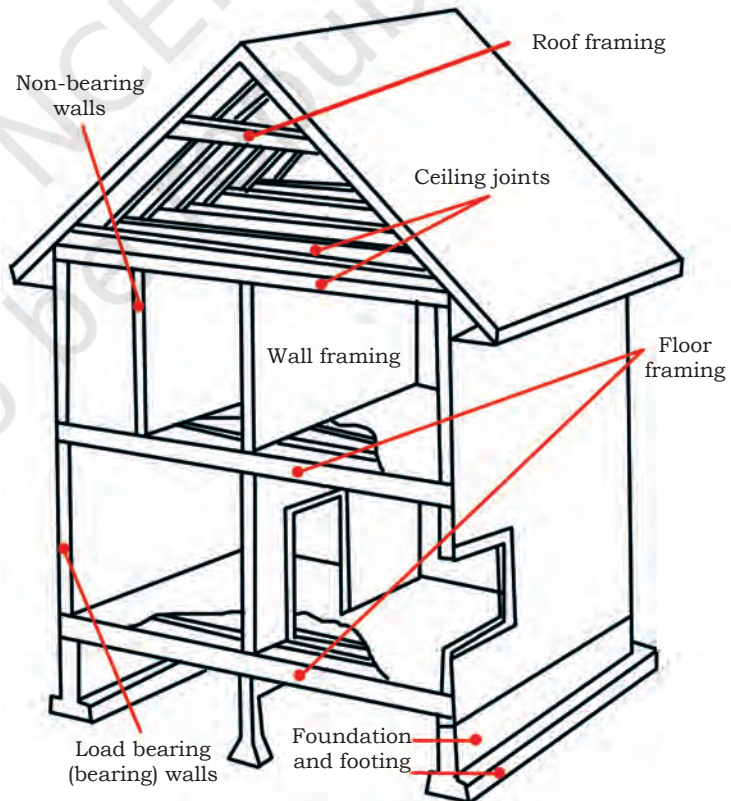
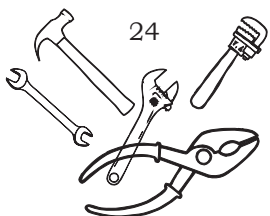

Fig.3.3: Basic elements of a building



CUTTING OR OPENING IN STRUCTURES

Drilling

A drill is a very powerful and potentially dangerous tool. A drill can easily make holes in the walls. However, the following precautions have to be kept in mind when using a drill.

1. Always check for any electricity cable running through the wall before starting to drill because it can be fatal.
2. Never wear loose clothes or dangling jewellery that could get entangled in the drill as one leans over to use it.
3. The drill bit becomes hot with use, so keep your hands off it.
4. Make sure you use the correct size of the drill bit for the type of wall you are drilling into.
5. If you are drilling into tiles, use a special tile drill bit and stick a little piece of masking tap or faucet over the area to stop the drill from wandering.
6. If you are drilling into a plaster board, tap the wall to find where it is not hollow. This will be where the wooden joint is—aim to drill only into this.
7. Always use a an extension cord made for this purpose, as a longer wire is needed for the drill and never pick up the drill by its flex.



Fig 3.4: Precautions to be taken while using a drill

NAILING

Nailing is done to fasten to a surface or to something else with a nail and a hammer. The different types of nails used are shown in Fig. 3.5.



Fig.3.5: Types of nails

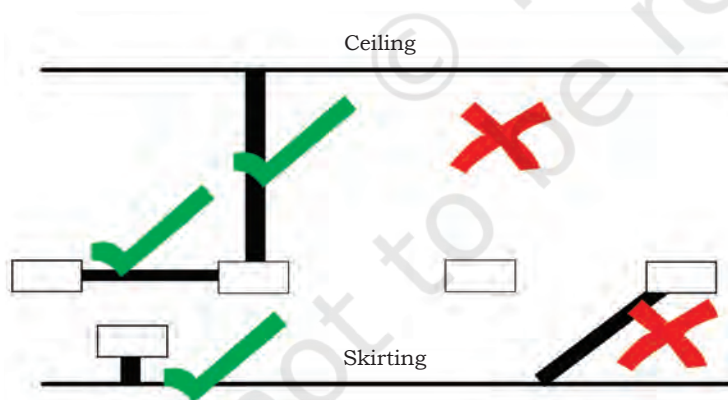

Fig.3.6: Core Cutting and Tools

CORE CUTTING

Chase or core is to bury (or, in builders' terms, chase) running cables or pipes up (or along) a masonry wall.

When a space is created in a wall for keeping the plumbing pipes. It is called chase. Chase cut-outs should always be vertical or horizontal between start and finish on the wall.

1. Never cut a chase at an angle between these two, nor step the channel.
2. While making vertical chase, care should be taken that the chase depth should not be more

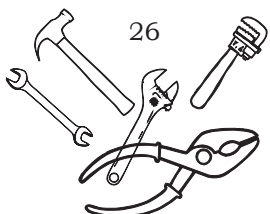

- than one-third of the wall thickness.
3. Similarly, for horizontal chase, the width of the depth of cut should be more than the sixth of wall thickness.
 4. Chases on opposite sides of a wall should not be in line, that is, 'back to back'.
 5. It should be noted, that if chasing in a cable, any new wiring circuit falls under Part P of the Building Regulations.

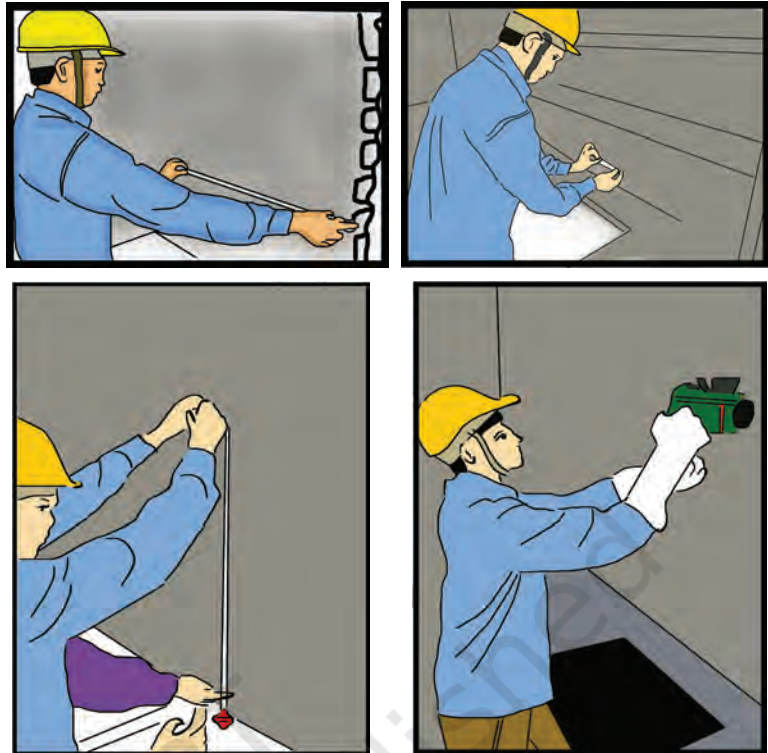

Fig. 3.7 (a): Types of Masonry Tools

BASIC MASONRY TOOLS

- (a) Trowels:** Trowel is used in masonry work. It is used to pick up mortar from a board and to place and spread the mortar into a brick or set of bricks. It secures a brick into the mortar by tapping. Sizes of trowel vary and can reach up to 11 inches in length and 8 inches in width. Masons prefer using short and wide trowels since they do not put excessive stress on wrists.
- (b) Chisels:** A chisel is used to cut bricks into specific sizes. Chisel width ranges from 2 ½ to 4 ½ inches.
- (c) Hammer:** A masonry hammer has a square face on one end for breaking; it has a sharp edge on the other for cutting. They are used to split hard bricks.

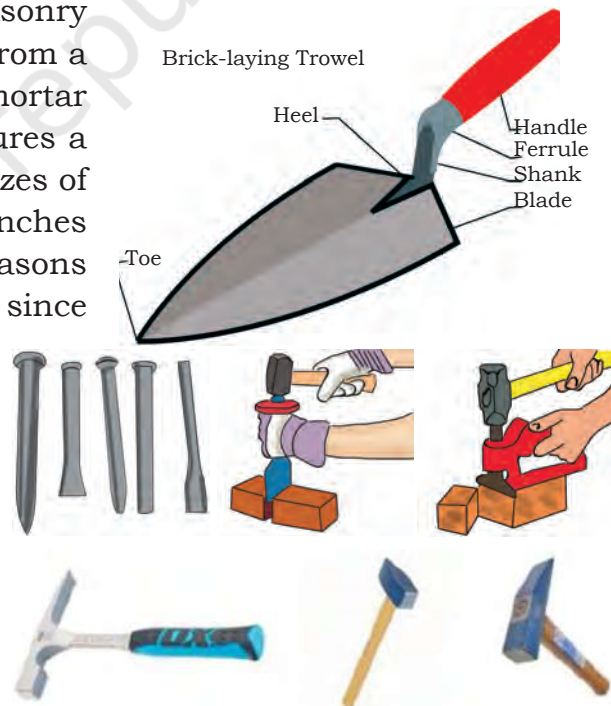

Fig. 3.7 (b): Types of Masonry Tools

PREPARATION OF BUILDING MATERIAL OR CEMENT MORTAR

Mortar is a workable paste used to bind construction blocks and fill the gaps between them. Mortar may be used to bind masonry blocks of stone, brick, cinder blocks, etc. Mortar becomes hard when it sets, resulting in a rigid aggregate structure. Modern mortars are typically made from a mixture of sand, a binder, such as cement or lime and water. Mortar can also be used to fix a masonry point when the original mortar has washed away. Mortar is mixed by hand in a mortar box. It should be as watertight as possible.

Method

1. Determining the type of cement will work best for the project.
2. Take fine sand and coarse sand. Take one part cement, two parts sand and three parts coarse sand into the wheelbarrow.
3. Mix the ingredients thoroughly with a spade to ensure they are well blended. Pour a small amount of water and make a paste.

Mortar Filling

Filling mortars can be used for a variety of projects and repairs. Mortar is a necessary filling component to join some home-building components together, such as bricks. It can also be used to patch holes and cracks in basements and foundations, hold a patio together or secure fence posts and mailboxes. Most mortars, a mixture of concrete, lime and sand, are easy to mix and use, in small and large batches. Good mortar is necessary for good workmanship and good masonry service because it must bond the masonry units into a strong well-knit structure.

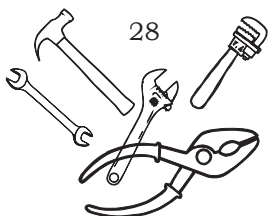

Practical Exercises

NOTES

Activity 1

Draw the components of a building.

Material required

1. Drawing copy
2. Rubber
3. Pencil
4. Scale
5. Drawing of building

Procedure

1. Select the drawing of a building.
2. Visit your school building.
3. Now, based on your knowledge of the components of a building, try to identify these components in your school building.
4. Draw the building drawing.
5. Label the components of building

Activity 2

Identify the parts of a hand-drill machine

Material required

1. Hand-drill machine
2. Drill bit
3. Chuck
4. Electrical Power switch

Procedure

1. Remove the power connection of the hand drill machine.
2. Identify the components of hand drill machine.
3. With the help of chuck open the holder of drill bit. Remove the drill bit.
4. Keep the drill bit back in the holder. Tighten the holder with the help of chuck.
5. Plug the wire into the electrical socket. Use the on-off switch of the drill machine and operate it.
6. Identify and make a list of all the components of this drill machine.

Activity 3

Practice the core cutting in a wall

Material required

1. Chisel
2. Hammer

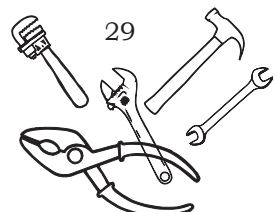

NOTES

3. Cleaning brush
4. Trowel
5. Scale
6. Old wall (unused)
7. PVC pipe

Procedure

1. Select the wall. Mark the wall.
2. Select horizontal length with the help of scale. Use the chisel and hammer and cut the grooves in the wall.
3. Fit the plumbing pipe in the wall. See the status of the pipe and whether the pipe inserted is loose or fit.
4. Clean the tool and keep the tool in proper place.

Check Your Progress

A. Short answer questions

1. List the components of a building.
2. Why is cutting made in the structure?
3. Why do we use a hand drill machine?

B. Multiple choice questions

1. Components of a building are _____.
(a) road (b) playground
(c) foundation (d) None of these
2. For cutting in the structure we do not use the tool _____.
(a) drill machine (b) chisel
(c) hammer (d) scale
3. Mortar is used for _____.
(a) binding masonry block
(b) binding construction block
(c) filling the gap between the blocks
(d) All of these
4. Which is not a part of trowel?
(a) Toe (b) Handle
(c) Ferule (d) Cone
5. Horizontal chase should not be deeper than the wall thickness _____.
(a) $\frac{1}{3}$ (b) $\frac{1}{4}$
(c) $\frac{1}{5}$ (d) $\frac{1}{6}$

C. Fill in the blanks

1. Mortar is made of mixture of sand, cement and _____.
2. Drill machine is used for making _____ in a wall.
3. Chisel is used for making _____ in the wall.
4. Nailing is done to _____ a surface.

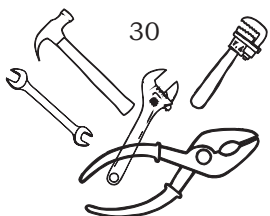

Plumber General Class 10

Unit 3: Basic Building Construction

Check Your Progress

A. Short answer questions

1. List the components of a building.
2. Why is cutting made in the structure?
3. Why do we use a hand drill machine?

B. Multiple choice questions

1. Components of a building are _____.
(a) road (b) playground
(c) foundation (d) None of these
2. For cutting in the structure we do not use the tool _____.
(a) drill machine (b) chisel
(c) hammer (d) scale
3. Mortar is used for _____.
(a) binding masonry block
(b) binding construction block
(c) filling the gap between the blocks
(d) All of these
4. Which is not a part of trowel?
(a) Toe (b) Handle
(c) Ferule (d) Cone
5. Horizontal chase should not be deeper than the wall thickness _____.
(a) $\frac{1}{3}$ (b) $\frac{1}{4}$
(c) $\frac{1}{5}$ (d) $\frac{1}{6}$

C. Fill in the blanks

1. Mortar is made of mixture of sand, cement and _____.
2. Drill machine is used for making _____ in a wall.
3. Chisel is used for making _____ in the wall.
4. Nailing is done to _____ a surface.

Unit



Pumps and their Installation



171020CH04

INTRODUCTION

Buildings of various heights are constructed for both commercial as well as residential purposes. The heights of these buildings vary from 15 to 1,000 feet. Water is carried with the help of water pumps fitted at the base of the building. A pump is a device that moves fluids (liquids or gases), or sometimes slurries, by a mechanical action.

TYPES OF PUMPS

Airlift Deep Well Pumps

These reliable and durable pumps are often used in deep dirty wells where the sand is acidic and alkaline. They are also used where simple pumps do not work as they collect more water. The compressed air enters the bottom of the pump and lifts the water above the well.

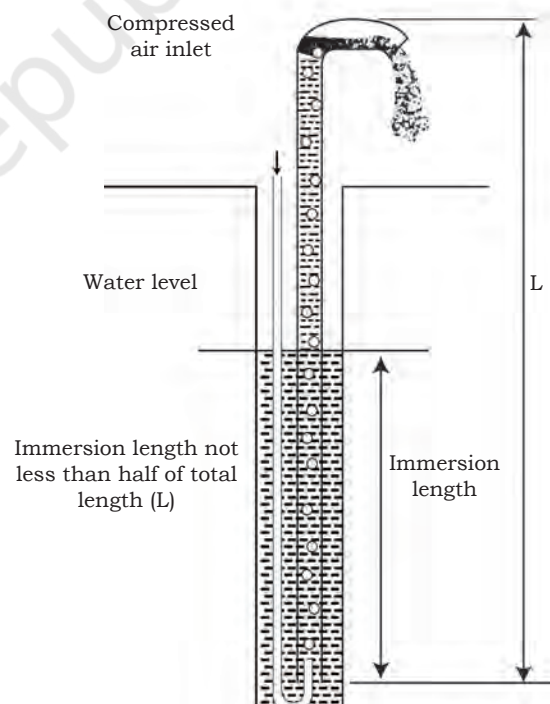

Fig. 4.1: Airlift deep well pump

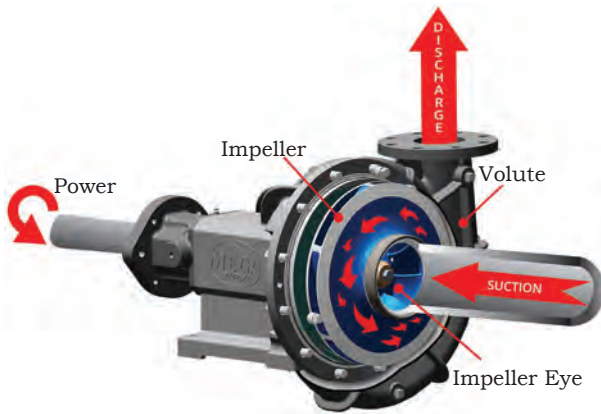

Fig.4.2: Centrifugal pump

Centrifugal Pump

These pumps are more useful than other pumps and work on the principle of centrifugal force. They are used to take water and other liquid to a higher level. These pumps are placed where less space is available. The initial fixing cost and operational cost is low and efficiency is satisfactory. These pumps are easy to operate and place and are available in many ranges and capacity. They neither have a discharging sound or a valve. They are available in single stage and multistage. Centrifugal pumps are cast in iron and have a steel shaft, bronze sleeves, cast iron impeller or cast iron vanes. Sometimes the impeller and vanes are in bronze.

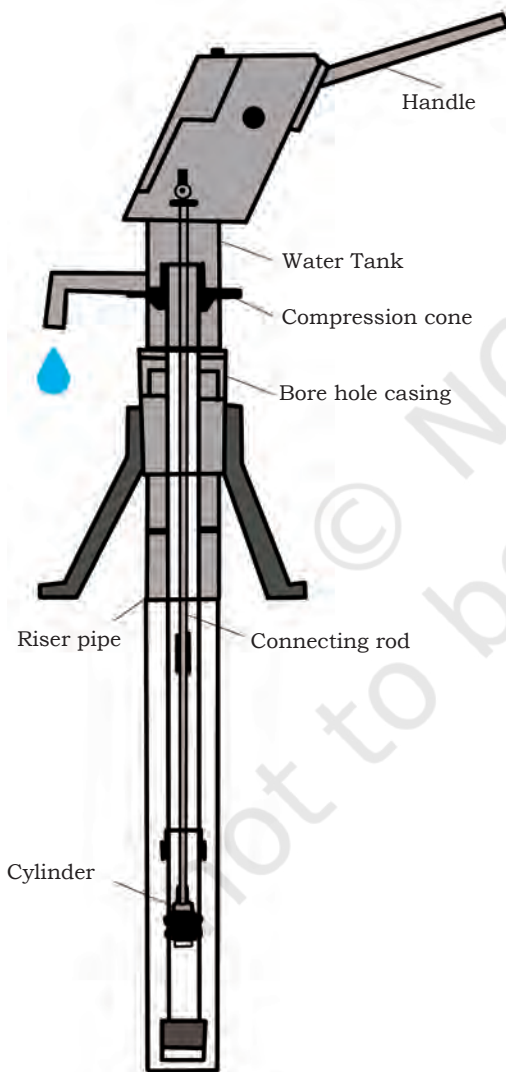

Fig.4.3: Reciprocating pump

Reciprocating Pump

This is called a handpump and are mainly used for domestic works. They are often used where a relatively small quantity of liquid is to be handled and where the delivery pressure is quite big.

Jet Well Pumps

They circulate water in loop systems and are available in several horsepower (HP) options for different pumping performance rates. Jet well pumps are mainly used in low capacity installation. They deliver water and water pressure to a household, cottage or small sprinkler systems.

(a) Shallow Well Jet Pumps: They are used when the pump is located above the water source, drawing water from a depth of 25 feet or less, vertically. They use a single suction pipe to draw from wells or surface water.

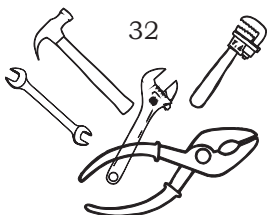

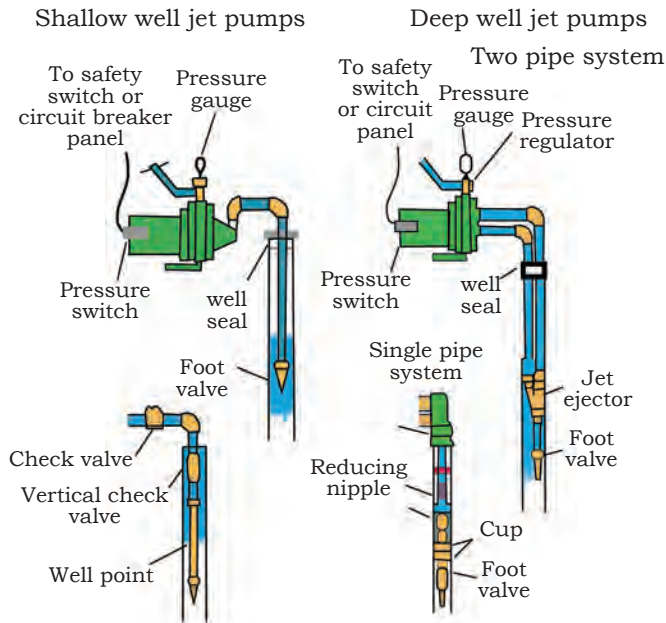

Fig. 4.4: Different types of jet well pump

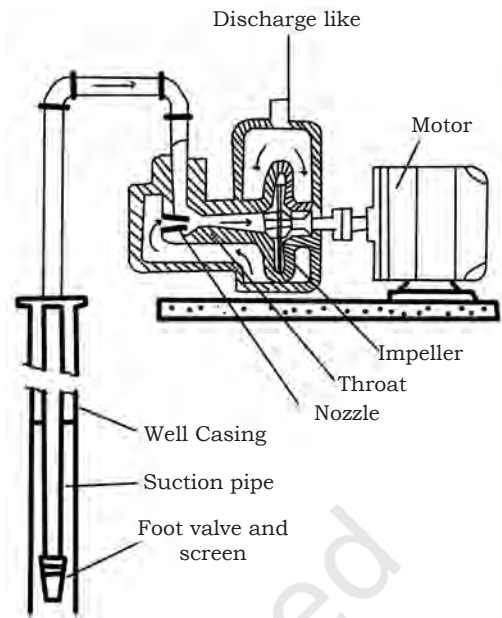

Fig.4.5: Convertible jet pumps

(b) Deep Well Jet Pumps: They are used when the pump is located above the water source, drawing water from a depth of 25 feet to 110 feet vertically.

(c) Convertible Jet Pumps: They are used for deep wells when installed with a jet assembly, built-in or attached to the pump. They are used when the pump is located above the water source, drawing water from a depth of 110 feet or less, vertically. They use two pipes on the suction side to draw water from wells. They are mainly used for household water supply from a well, driven point system, or open water source. Pumps should be used with a standard or pre-charged pressure tank.

These pumps are mainly used to draw a lot of water, oil or liquids.

Rotary Pumps

In rotary pumps two gears are placed. These gears rotate from the centre. They do not have a valve and do not lift water where sand

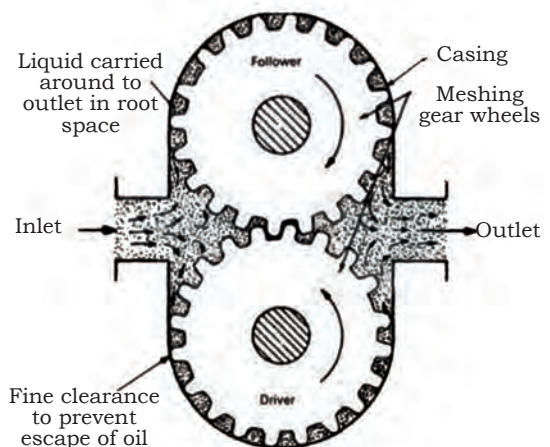

Fig.4.6: Rotary pumps

and silt are mixed in water. Their capacity to pump water totally depends on the tightening of their body. They pump water without any obstruction and low maintenance cost. Their work capacity is 60 to 80 per cent.



Fig. 4.7: Water Meter

WATER METER

Water metering is the process of measuring water use. The purpose of meter is to measure the quantity of water consumed by a building. There are different types of meters to measure different quantities of water.

For example, a 15mm size meter measures 2000 litres of water per hour, while a 50mm size of water meter can measure 15,000 litres water per hour.

Advantages

1. This quantifies the amount of water consumed by the people.
2. In conjunction with volumetric pricing, it provides an incentive for water conservation.
3. It helps to detect water leaks in the distribution network, thus providing a basis for the reduction of non-revenue waste.
4. It is a precondition for quantity — targeting water subsidies to the poor.
5. Quantity consumed is generally regarded as the fairest way to pay.
6. This provides a strong signal to users to manage water consumption and reduce wastage.
7. Helps to detect leakage.

Disadvantages

1. Uncertainty over to which extent meters actually reduce consumption. The evidence for optional metering in particular is inconclusive, and

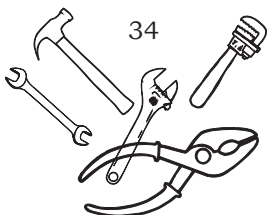

metered customers may be less likely to reduce consumption during times of drought.

2. Potential impacts on affordability, since less well-off customers may limit their use to save money with a consequent risk to health or hygiene. There is a tension between pricing to encourage customers to use water wisely and making water affordable for all.
3. The difficulty of individually metering some properties, such as those with a shared supply.
4. The historic cross subsidy, where the cost of metering has been shared amongst non-metered customers, is gradually exposed. This leaves a smaller proportion of the remaining unmetered customers paying a higher cost.

TYPES OF WATER METERS

There are various types of water meters, which are selected on the basis of requirement of the place. Some of these are as given below.

Gear Type Water Flow Meter

Generally, all residential water meters are of positive displacement type. Displacement water meters measure how much water occupies a given space over a preset time. These can in turn be gear meter or oscillating piston or nutating disk meter-type. Here, the water is made to enter into a chamber from which it is let out only when the chamber fills-out. By doing so, one can estimate the rate of flow of water. These meters are used when the water flows at a moderately low rate.

Velocity Water Meter

In these meters, the rate of flow of water is determined by monitoring the speed at which the water flows. Jet-type water meters are suitable for low flow rate measurements, while turbine-type flow meters are suitable when flow rates are high.

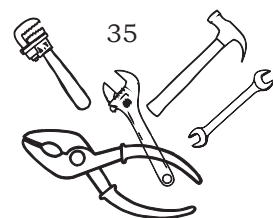

Electromagnetic Water Meter

Water meters can also measure the flow rate of water by using Faraday's law of induction. Such meters are referred to as electromagnetic water meters and are usually used when one needs to measure unclean or untreated or waste water.

Transit Time Type Water Meter

Water meters can also be of ultrasonic type in which the rate of water flow is measured by using SONAR technique. Here the sound waves are sent through the flowing water to measure its velocity. Once velocity is known, one can determine the associated rate of flow of water as the cross-sectional area of the meter body would be known in prior.

Practical Exercises

Activity 1

Draw the diagram of pumps

Material required

1. Pen
2. Pencil
3. Copy
4. Water pump

Procedure

1. Identify the water lifting pump at home or school.
2. Identify the components of pumps.
3. Discuss with your classmates regarding components of the pump.
4. Draw the figure of the pumps.

Activity 2

Visit to the community water storage tank

Material required

1. Pen
2. Pencil
3. Copy
4. Water pump

Procedure

1. Teacher will identify water storage in school area.
2. Teacher will take permission from Principal and in charge of water storage tank for visit.
3. During the visit student will note the different type of pump.
4. Note down the different types of water tank storage capacity, etc.

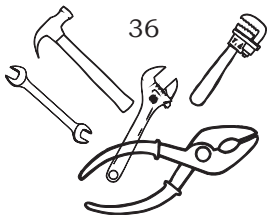

Activity 3

Measuring the water meter reading

Material required

1. Water Measuring meter
2. Copy
3. Pen
4. Pencil
5. Stop watch

Procedure

1. Visit a site where water meters are fitted.
2. Identify the components of the water meter.
3. Read the reading of the water meter.
4. Note down the water meter reading.
5. Discuss with friends and teachers about the water meter.

Check Your Knowledge**A. Short answer questions**

1. Differentiate between shallow jet well pumps and deep well pumps.
2. List the advantages and disadvantages of installing a water meter.
3. Draw the parts of centrifugal pumps.

B. Multiple choice questions

1. Water pumps are used to _____.
 - (a) lift the water
 - (b) carry the water
 - (c) transfer the water
 - (d) All of the above
2. Which of these pumps work on the principle of centrifugal forces?
 - (a) Deep pump
 - (b) Lift pump
 - (c) Centrifugal pump
 - (d) None of the above
3. Reciprocating pump is used for _____.
 - (a) domestic work
 - (b) industrial work
 - (c) mass work
 - (d) None of the above
4. Deep well jet pumps draw the water from a depth of _____.
 - (a) 25 to 50 feet
 - (b) 25 to 90 feet

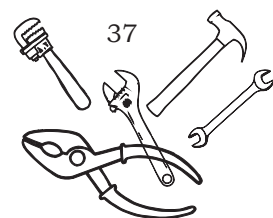

- (c) 25 to 100 feet
 - (d) 25 to 110 feet
5. How many gears are placed in a rotary pump?
- (a) 2
 - (b) 4
 - (c) 5
 - (d) 6
4. Which of the following pumps are also known as hand pumps?
- (a) Centrifugal pumps
 - (b) Reciprocating pump
 - (c) Airlift deep well pump
 - (d) Jet pump

C. Fill in the blanks

1. A pump is a device that moves fluids, slurries by a _____.
2. Shallow well jet pump draw water from a depth of _____ feet.
3. Water meter is used to measure the consumption of water in a _____.
4. A centrifugal pump is used for transferring the _____.
5. Positive displacement meters are _____ common for homes and small business.

© NCEERT
not to be republished

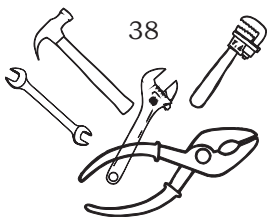

Plumber General Class 10
Unit 4: Pumps and their Installation
Check Your Progress

A. Short answer questions

1. Differentiate between shallow jet well pumps and deep well pumps.
2. List the advantages and disadvantages of installing a water meter.
3. Draw the parts of centrifugal pumps.

B. Multiple choice questions

1. Water pumps are used to _____.
(a) lift the water
(b) carry the water
(c) transfer the water
(d) All of the above
2. Which of these pumps work on the principle of centrifugal forces?
(a) Deep pump
(b) Lift pump
(c) Centrifugal pump
(d) None of the above
3. Reciprocating pump is used for _____.
(a) domestic work
(b) industrial work
(c) mass work
(d) None of the above
4. Deep well jet pumps draw the water from a depth of _____.
(a) 25 to 50 feet
(b) 25 to 90 feet

Unit



Performing various Plumbing related Operations and Procedures



171020CH05

INTRODUCTION

While carrying out plumbing repairs, it is important that the plumber has sufficient knowledge of the cause of damage to the plumbing system. Some of the causes that must be kept in mind are listed below.

Causes of Damage to the Pipeline and Plumbing System

1. Defective jointing material
2. Direct strike on the body of the pipe with any sharp edge, while jointing
3. Slipping of jointing material, like rubber ring or lead, etc.
4. Corrosive nature of soil, causing damage to the external surface of the pipe
5. Loss of support or anchorage (horizontal or vertical), both in case of pipes embedded and those laid above the ground level
6. Movement of soil due to filled soil, mining
7. Movement of soil while work such as laying of pipes or cables, etc., is taken up
8. Changes in soil moisture or water table conditions
9. Expansion—severe compression, end crushing

10. Contraction—pull out or separation of joint
11. Pipe blockages and splits
12. Excessive test pressure
13. Pressure surge, water separation, vacuum
14. Extending pipe connections without proper precautions
15. Damage to the internal surface of pipe as well the lining material

The following procedure should be followed for the repair of pipes.

1. Location and demarcation
2. Repair planning
3. Repair work—selection of most appropriate method for repair
4. Testing of ‘dry’ repair
5. Restoration

Steps for Repair

1. Inspect the site and ascertain the nature of the failure.
2. Assess any possible damage that may arise and take steps to face such situations.
3. Investigate the access to the site so as to plan the arrangement of plant and equipment.
4. Locate isolating valves for proper control of requisite activities required for repair work

TYPES OF REPAIR

A ‘wet’ repair is defined as a repair which can be achieved while maintaining a nominal pressure in the pipeline. Split collars or identical fittings can be installed in this way if the conditions are favourable.

A ‘dry’ repair is defined as one in which the main is completely isolated and drained out. It is necessary to stop water supply or make ‘dry’ main while cutting and replacing the defected portion. It will save the water from draining.

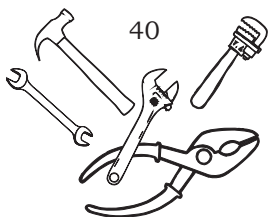

Repair of Small, Local Defects—‘Wet Repair’

For small local defects, such as pinholes, a single split collar or wraparound clamp may be all that is required. The repair can be carried out at as a ‘wet’ or ‘dry’ operation. In case of ‘wet’ repair, care should be taken to maintain a steady, gentle flow so as not to dislodge the sealing elements.

Cut Out—‘Dry Repair’

For a more extensive damage, for instance, a longitudinal fracture, a section of pipe is cut out and replaced by the use of two appropriate couplers. If the full extent of the fracture is not clearly defined, cuts should be made at least 300 mm beyond each end of the visible crack or defect. In case of any doubt, the full length of the damaged pipe should be replaced. This necessitates cutting out the joint at both ends of the affected pipe. Thus, the repair normally requires two replacement pipe sections and three couplers.

Replacement Repair

1. Carry out correct measurements and give allowance for expansion
2. All cuts should be made clean and square. This means that there must be uniformity in cutting and the cuts must be free from dirt and burr, etc.
3. In AC pipes, cuttings should be avoided.
4. All cut edges should be prepared to the manufacturer’s recommendations.
5. Both exposed ends of the existing pipe should be treated similarly.
6. Couplers should have their sealing rings lubricated, if recommended.
7. Correct expansion gaps should be allowed.
8. Good alignment is essential, particularly if narrow couplers are used.
9. All couplers and collars should be centralised.
10. Tighten all bolts evenly.
11. Do not overtighten bolts or compression joints.

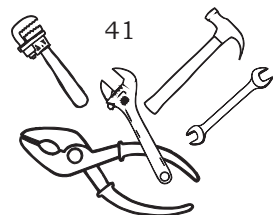

12. Restore any damaged coatings on the parent pipe.
13. Ensure full protection to the bolts and any exposed bare metal before burial.

SITE MANAGEMENT

Record of Repair

While the repair is still visible, the details of repair should be recorded. This could include any leakage that may have been plugged or the change of pipeline, if any.

Site Cleanliness

During the repair work, the area should be kept as clean as possible. All debris and contaminants should be removed from the site and the contamination of the trench from plant, equipment or any other potentially hazardous materials must be avoided.

Prevention of Contamination During Repair Work

Clean and spray with disinfectant, on all surfaces that come into contact with potable water, including the broken main, repair fittings and replacement pipe. Ensure that the contaminants do not enter the main where it is cut for repair. After completing the repair, flush the main at the nearest hydrant to remove any dirt, etc.

Disinfection Procedure

For small repairs, which do not require the main to be cut, the fracture should be cleaned. This, along with the repair collar should be sprayed with disinfectant. For major repairs requiring cut-out, care must be taken to prevent contamination.

Clear Site

On completion of the work, all material and protective barriers should be removed from the site and the working area should be left clean and tidy. All records of repair should be completed and submitted.

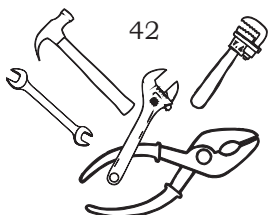

REPAIR OF FIXTURES

Bibcock

It is commonly referred to as the tap or faucet and it is the most frequently used water supply fitting. There are taps and faucets of many designs available in the market. While repairing, it is also advisable to read the manufacturers' instructions.

The defects commonly encountered in the functioning of taps and faucets, its causes and remedial measures to be taken are listed below.

Defects

1. Water drips from the tap even when it is tightly closed.
2. Water flows from around the spindle or stuffing box
3. Difficulty to turn on or off the tap.
4. The spindle slips continuously when the tap is turned on and off.
5. There is a lot of noise in the tap when turned on.

Causes

1. Worn out or defective washer.
2. Accumulation of grit (small, loose particles of stone or sand), dust or other foreign matter.
3. Defective seating.
4. Gland nut (a component of the tap or faucet) is loose.
5. The packing in the stuffing box is defective.
6. The packing in the stuffing box is dry.
7. The spindle is bent.
8. The spindle thread is worn out.

Repair

1. Close the water supply to the water tap or bibcock.
2. With the help of a vice grip, hold the body of the bibcock.

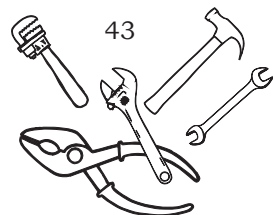

3. Use the wrench to remove the head of the tap by simply tapping.
4. Check the spindle; if it is worn out, replace it.
5. Remove the old washer of the spindle.
6. Replace with a new washer.
7. Fit the head back to the body.
8. Open the water supply and check the leakage, if any.

Stopcock (Stop Tap or Stop Valve)

It is similar in construction to a bibcock, except that it is placed in the pipeline instead of the outlet. The defects commonly encountered during the functioning of stopcock, its causes and remedial measures to be taken, are listed below.

Defects

1. Water drips from the stopcock even after it is firmly closed
2. Water flows from around the spindle or stuffing box screw
3. It is difficult to turn on or turn off the stopcock.
4. The spindle slips down continuously when the stopcock is turned and the tap does not close.

Causes

1. Worn out or defective washer
2. Accumulation of grit, dust, or other foreign matter
3. Defective stopcock seat
4. The gland nut is loose
5. The packing in the stuffing box is defective
6. The packing in the stuffing box is dry
7. The spindle is bent
8. The spindle thread is worn out

Repair

First, we have to find exactly where the stop valve or tap is leaking. Mostly, there could be three possible places where a stop tap may leak.

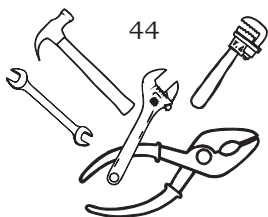

1. Compression nuts
2. Gland nut
3. Head gear joint

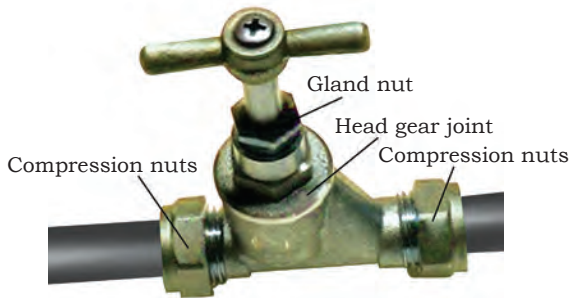

Fig. 5.1: Parts of a stop tap or a valve



Fig. 5.2: Opening of a compression nut

(i) *Compression nuts:* If water is leaking from one of the two compression nuts, then tighten the nuts and this should stop the leakage. Grip the body of the tap with water pump pliers and then tighten the nut by turning it clockwise, using a spanner.

If leakage does not stop, then wrap some polytetrafluoroethylene (PTFE) tape (Teflon or plumber's tape) around the nut. Prior to repairing, the water supply should be stopped.

Once this is done, you can loosen the nut by turning it anti-clockwise. Wrap some PTFE tape around the nut and then re-tighten the nut.

(ii) *Gland nut:* If the leak is on the gland nut, first try tightening the gland nut with a spanner. This may stop the water from leaking (Fig. 5.3).



Fig. 5.3: Tightening of a gland nut

The gland nut can be removed and repacked without the water being isolated. It is advisable to use two suitable spanners, one to hold the large nut on the stop tap and one to undo the gland nut. The nut will undo in an anti-clockwise direction.

Slide the gland nut up the spindle and then remove any old bits of packing from the gland. If the leak is on the head gear joint, we have to stop the water and then undo the nut and apply some PTFE tape to the threads (Fig. 5.4).



Fig. 5.4: Removing bits from a gland nut

Replacing stop tap washer

If water is still leaking through the tap then it is possible that it is worn out or damaged. Replace the washer in the following manner.

1. First stop the water supply to the tap (Fig. 5.5a).
2. Grip the body of the stop tap with a pair of adjustable water pump pliers. Then, with a suitable spanner, turn the large nut in the centre of the stop tap anti-clockwise (Fig. 5.5b).



Fig. 5.5: (a) Opening of a large nut

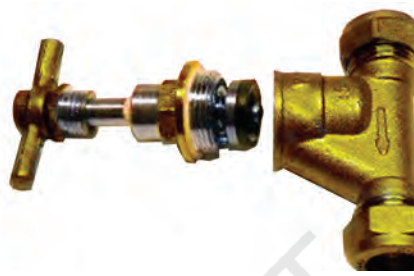

Fig. 5.5: (b) Separating body of a tap



Fig. 5.6: Checking the washer



Fig. 5.7: Removing the washer



Fig. 5.8: Replacing the rubber washer

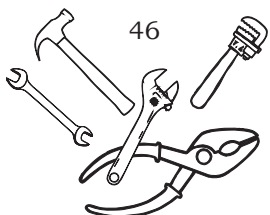

Fig. 5.9: Applying tape

3. Then, unscrew the handle and assembly from the body of the tap (Fig. 5.6).
4. Now remove the rubber washer at the end of the assembly (Fig. 5.7).
5. Replace the rubber washer with a new one. This simply pushes onto the end of the assembly (Fig. 5.8).
6. Wrap some PTFE tape around the thread of the assembly (Fig. 5.9).
7. Screw the assembly into the body of the stop tap and re-tighten using the water pump pliers and suitable spanner (Fig. 5.10).



Fig. 5.10: Assembly attached to the stop tap



Water Supply Fitting—Gate Valve

Gate valve is one of the most common valves used in the main supply lines of a water supply system and pump-lines. The commonly encountered defects during the operation of gate valves, their causes and remedial measures to be taken are listed below.

Defects

1. Water flows from around the stuffing box screw
2. The valve is hard to turn on or turn off.
3. The spindle rotates continuously and the gate valve does not close.

Causes

1. The gland nut is loose.
2. The packing in the gland nut is defective.
3. The spindle is bent.
4. The spindle thread is worn out.

Repair

1. Tighten the dry gland nut.
2. Renew the defective packaging with asbestos hemp and water pump grease.
3. Replace the bent spindle with a fresh one.
4. Replace the worn-out spindle.

Cistern

Repair of cistern

As you know, water is stored in the cistern, and if there is leakage in the cistern, the following steps should be followed for repairing.

(i) *Inspect the toilet:* If water is not flushing, it means the flush is defective. There may be a broken connection between the flush handle and the flushing mechanism. Remove the cistern lid and carefully set it aside. Check all components and find the defective portion.

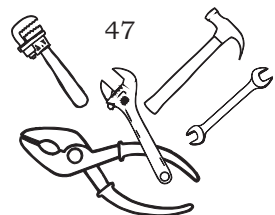



(a)

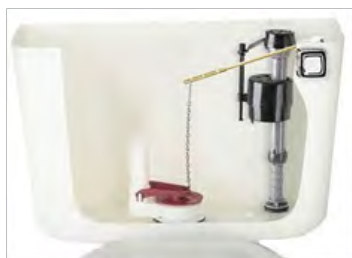

(b)

Fig. 5.11 (a, b) Cisterns

(ii) *Repair the handle:* Sometimes, in the toilet cistern, the flush handle is loose and not connected to the other part. It may be due to a worn out connector. Thus, the handle gets dropped. We have to replace the damaged connector. With the help of a wrench, open the nut holding and remove the handle stem from the cistern and replace it with the same specification of handle stem. After undertaking the repair work, test the flush while the lid remains off to make sure it works properly.

(iii) *Replace the toilet siphon:* If the toilet cistern flush handle is intact and working properly, the problem is likely to lie with the flush diaphragm, which is at the base of the toilet siphon. Toilet siphon is the largest section of the mechanism within the toilet in which water is drawn in and flushed out.

Disconnect the water supply to the toilet and flush out the water until the cistern is empty. Once empty, locate the clips that hold the flush handle to the siphon and the siphon to the rear of the cistern. The entire mechanism can then be lifted out of the cistern to see all components. The entire toilet mechanisms are available in the local market and can be purchased in a kit. Kit consists of all the components needed for replacement. Reassembling the mechanism is simply reversing the procedure used to disassemble it. After reconnecting all the fasteners and components, turn on the water supply and check the cistern by refilling the water. See if it is working properly.

Repair of float valve

The float valve is used to stop the level of water in the water tank or cistern of the toilet tank.

1. Open the tank.
2. Check the parts of the float valve.
3. If the floating ball is punctured, replace with a new ball.
4. If the rod of float ball is bent, then straighten it or replace it.
5. Adjust the level of the float ball for water level.
6. Check and test with off and on switch.

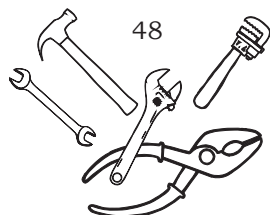

Water Closets

Most water closets are made of vitreous China, which might crack if exposed to extremely hot water. A plunger will normally handle simple toilet clogs. Another method of cleaning a water closet trap or toilet is the use of an auger with an adjustable, crank-type handle. Known to plumbers as a 'snake', the spring steel coil is easily worked past the trap and down the pipe. A three-foot auger is inexpensive and will quickly drill through most clogs. Use the auger carefully. Careless handling may crack the toilet.

Toilet Tanks

It is a general complaint that water continues to leak into the closet bowl of the toilet tank. It may be due to failure of mechanism of toilet tanks. Let us understand the possible reasons of water leakage.

One, when there is little humming noise or water continues to leak after filling the water tank, it means that there is leakage from the water tank. It may be due to improper placement of the flapper on the water discharge opening. Sometimes, the seat or collar of the discharge opening gets corroded due to sticking of dust, etc. To check the leakage of water, this corroded portion of the collar should be removed by rubbing with a file or scraper. Uniformity of collar will make uniform force on the stopper. Similarly, the wire of the float valve gets bent, leading to leakage of water. This wire should be straightened so that the ball is lifted properly and the water flow is stopped. Float valve should be regularly checked and it must be seen that it does not get shortened or punctured. If so, it should be immediately replaced. To check the overflow, a bent pipe is also inserted in the tank so that overflow of water is seen properly. Overflow pipe is generally kept 3 to 4 inches above the desired water level of tank. This will alert the user to check why water is getting lost, and take appropriate action.

Fittings

You must have observed that taps, faucets and valves are important features of the plumbing system and are used mostly for all purposes. To increase the life of these

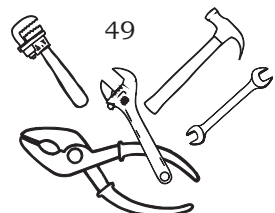

fittings, good quality material must be used. Generally chrome-plated brass fittings are mostly used for better quality and long life. These fittings can be easily cleaned with water and soap solutions.

It has been observed that metal chromium gets easily dissolved with the use of hydrochloric acid or sulphuric acid. Muriatic acid is effective for cleaning tiles where nickel-plated fittings are used. For chrome-plated fittings, cleaning of bathroom tiles should be done with oxalic acid. Acid fumes generated during the cleaning process also deteriorate the quality of fittings, despite being covered with clothes. Nowadays, polished brass-based fittings and trim are used mostly due to better quality.

The use of solvent-based chemical solution should not be promoted for cleaning of tiles and fittings. It is generally suggested that manufacturer's recommendation regarding the maintenance of fittings should be adopted and followed.

Taps and Faucets

Washerless Taps and Faucets

These can be either the single handle or two handle type. In these, the control of water flow is done by a replaceable cartridge or arrangement of seals that allows water flow when the holes or ports are lined up in a proper configuration. Giving the handle an extra hard twist to stop water flow will be ineffective. This type of a tap or faucet does not use compression strength to stop water flow. However, when removing the stem, always check the seat inside the body of the tap and the brass ring that the washer grinds against. The tap or faucet seat can be worn or grooved, making the washer replacement ineffective within days. The washer and seat are the two parts of a compression type tap or faucet that receive the greatest amount of wear. Pad a smooth jawed wrench with a cloth, then, using the padded wrench, unscrew the large packing nut and turn out the tap stem. Then, with a screwdriver that fits the screw slot closely, remove the screw from the bottom of the stem and pry out the worn washer. Next, clean the washer seat or compartment. When this is done, insert the new washer of the correct

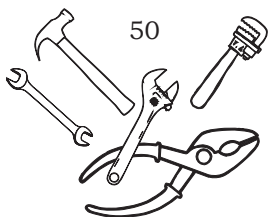

size and composition for hot or cold water. Some of the newer, soft neoprene washers are for both hot and cold water and have a long life. The washer should fit snugly without having to be forced into position. After inserting, replace the screw and tighten. It is usually just as expensive to renew a seat as it is to buy a new tap, unless it has been made with renewable seat. Check with your plumber about a badly worn tap. With cloth over finger, clean the valve seat inside the tap or faucet. The edge should be smooth and free from deep nicks. If you find it badly worn, you will probably need to replace the seat or have the entire tap or faucet replaced by the plumber. Otherwise, it will leak again. Next, replace the tap or faucet stem and turn it in. Tighten the packing nut. Be careful not to tighten the nut more than necessary to stop seepage around the tap or faucet stem.

Sink

Sink bowls come in many different materials. Although enamelled cast iron remains an attractive and durable product, many people today are choosing bowls made of stainless steel, and other solid surface materials for their added durability and stain resistance. The important thing to remember is to follow the manufacturer's instructions pertaining to the material of bowl. Use a non-abrasive cleaner. Constant use of abrasive cleaners can eventually wear the finish down, making it much more porous and susceptible to stains. This can also happen with enamelled, cast iron tubs over a long period.

Washbasin

In our homes, washbasins and kitchen sinks get choked due to some obstruction from waste material or dirt. As a result, water can not flow smoothly. Thus, many small tools like plunger, auger, force cup and wire are used for clearing the obstruction.

Noises in the Plumbing System

In an old plumbing system, different types of noise may be created due to some defect. These could include whistling, chattering or hammering. Whistling is the



Fig. 5.12: Removing clogs in a washbasin



Fig. 5.13: Use of tools for removing clogs

most common noise heard in a plumbing system. It is created when water flows speedily through a pipe of a smaller diameter. It can be eliminated by inserting air pipe in the wall where supply wales enter the plumbing chambers. When water comes in contact with broken, loose pipes or pipes rubbing each other, a chattering noise is created. Due to sudden closing of tap or faucets, a thump in the water pipe is created which makes a hammering noise. These noises can be checked with proper intervention.

Odours in the Plumbing System

A well-designed and correctly installed plumbing system gives out no odour. Odours are most likely to arise from leaks in the waste or vent piping or from traps which have lost their water seal. In an incorrectly installed system, there is a possibility for odours to result from defects in the system, particularly if the fit is not properly vented.

Repair of Different Types of Pipes

Some of the methods of repair for different types of pipes are given in the following table.

Table 5.1: Different types of pipes and methods of repair

Material		Cast Iron
Burst	Action	Repair
Joint failure	Enclose joint Two couplers	Special joint clamp Two couplers and new section
Brittle failure	Remove section/joint Enclose failure	Two couplers and new section Repair collar or clamp
Corrosion	Remove section/joint Rehabilitation	Two couplers and new section Slipping, etc. Repair collar or clamp
Material		Ductile Iron
Burst	Action	Repair
Joint failure	Enclose joint Remove section/joint	Special joint clamp Two couplers and new section
Extensive pinholing	Rehabilitation technique Remove section/joint	Slipping, etc. Two couplers and new section
Ductile failure	Remove section/joint Enclose burst	Two couplers and new section Repair collar or clamp
Localised pinholing	Enclose burst	

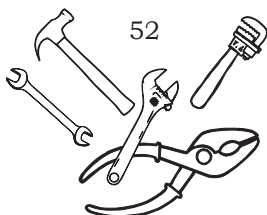

Material		Steel
Burst	Action	Repair
Extensive pinholing	Rehabilitation technique Remove section/joint	Slip lining, etc. Two couplers and new section
Joint failure	Remove section/joint Enclose joint	Two couplers and new section Special joint clamp
Isolated pinholing	Enclose burst	Patch and weld Repair collar or clamp
Isolated pinholing	Enclose burst	Patch and weld Repair collar or clamp
Material		Prestressed Concrete
Burst	Action	Repair
Surface softening	Remove complete length/ joint or cracking	Two couplers and new pipe section
Joint failure	Remove complete length/ joint Enclose joint	Two couplers and new pipe section Special joint clamp
Material		Polyethylene/P.V.C
Burst	Action	Repair
Fast crack propagation	Remove damaged section	Two couplers and new section
Brittle failure	Remove damaged section Enclose burst	Two couplers and new section Repair collar or clamp
Joint failure	Cut out joint	Two couplers and new section

Plan and Schedule Routine Maintenance, Repairs and Modifications

1. As per the manufacturer's recommendation, check the need for repair, or replacement requirement of plumbing items.
2. Read the existing warranties and service agreements made by the user prior to start maintenance or repair work.
3. Prepare the estimate cost of the work to be done and collect a quotation if required.
4. Collect the written approval of the work to be carried out by the concerned person.

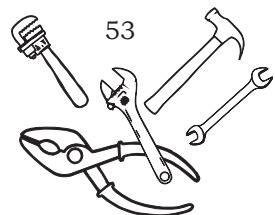

5. Detailed information of the site must be collected and check the requirement of access to the site.
6. Identify and select the labour, tools and machinery required for activities.
7. Qualification and skill experience of manpower should be properly checked.
8. Availability of labour should be scheduled as per need.
9. Availability of tools and equipment, machinery should be ensured as per work in advance so that work does not suffer.
10. Prior approval from the concerned department should be taken so that there is no further disturbance during work.
11. Plan appropriate time for installation so that minimum disturbance of operation occurs.
12. Detailed information of weather should be collected so that contingency planning can be done.
13. Mention in detail about the schedules, jobs to be carried out in work order, etc.
14. Submit the bill and final report of execution of work to the customer.

Practical Exercises

Activity 1

Change of washer in a bibcock

Material required

1. Bibcock
2. Washer
3. Screwdriver
4. Spanner
5. Pliers

Procedure

1. Select a bibcock.
2. Open its top cover with a screwdriver.
3. Open the nut with the help of a spanner and plier.
4. Take out the spindle.

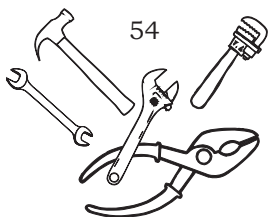

5. Remove the old washer.
6. Replace old washer with a new one.
7. Fix the spindle back and tighten with the help of a spanner and plier.
8. With the help of a screwdriver, tighten the spindle in the body and test it.

Activity 2

Cleaning the blockage of a washbasin

Material required

1. Washbasin
2. Plunger
3. Snake wire

Procedure

1. Insert the snake wire in the hole of a washbasin.
2. With the help of a plunger, suck the dirty material.
3. Put water in the washbasin.
4. If water goes out smoothly, it means there is no blockage.

Check Your Progress

A. Short answer questions

1. Why is repair necessary in the plumbing system?
2. List the steps required for checking the flush system of a western latrine.
3. What are the reasons for noise in a plumbing system?
4. What is the reason for odour in a plumbing system?

B. Fill in the blanks

1. Water closets are made up of _____.
2. Wet repair is done when pressure in pipe is _____.
3. Bibcock is commonly referred to as _____.
4. A gate valve is used for _____.

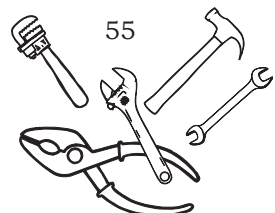

Plumber General Class 10

Unit 5: Performing various Plumbing related Operations and Procedures

Check Your Progress

A. Short answer questions

1. Why is repair necessary in the plumbing system?
2. List the steps required for checking the flush system of a western latrine.
3. What are the reasons for noise in a plumbing system?
4. What is the reason for odour in a plumbing system?

B. Fill in the blanks

1. Water closets are made up of _____.
2. Wet repair is done when pressure in pipe is _____.
3. Bibcock is commonly referred to as _____.
4. A gate valve is used for _____.

Unit



Maintaining a Healthy, Safe and Secure Work Environment



171020CH06

An accident can occur anywhere or everywhere if we do not follow or maintain a secure environment. Accidents occur due to improper handling of tools, machine or equipment. The fatal injury rate for the construction industry is higher than the national average in this category for all industries. “About 48,000 workers die in India due to occupational accidents, of which 38 fatal accidents take place every day in the construction sector. Construction industry contributes to 24.20% of occupation fatalities, the highest in the country annually,” the British Safety Council (BSC) has said. Construction sector is the number one sector employing maximum number of employees. It is important to that workers are oriented about hazards and their controlling them.

Within the plumbing industry, the plumber may be involved in a range of work activities, such as,

1. installing hot water and gas services,
2. replacing guttering and downpipes,
3. laying and connecting water and sewage pipes and
4. fixing washbasin or sewage blockage.

Hazards to the Plumber

1. Use of powered tools
2. Use of hand tools
3. Falls
4. Manual handling
5. Hazardous substances
6. Biological hazards
7. Electricity
8. Burns
9. Trenches and confined spaces
10. Sunburn and heat stress
11. Scaffolding

Use of Power Tools

Power tools are used to carry out everyday tasks in the plumbing industry. Power tools are operated by an additional power source, using electric motors, engines, compressed air, etc. These can present serious risks if not used and maintained correctly. The most common injury that can occur while using power tools is to the hands and fingers, which could get cut, broken or crushed. Eye injuries are often caused by pieces of material flying off while being cut or ground by power tools. Such injuries can lead to long periods away from work and sometimes result in permanent disability. Some commonly used power tools include air compressor, pneumatic wrench, power drill machine, etc.



Fig. 6.1: Using power drill machine



Fig. 6.2: Hand Tool

Use of Hand Tools

These tools are manually operated and do not rely on a power source. Some commonly used hand tools include hammers, pliers, monkey wrenches, etc. These can also be dangerous if they are not used correctly. A common cause of accidents with hand tools is using the wrong tool for the job. For instance, if one uses a wrench for hammering work then it may hit one's fingers and cause injury. Thus, one should use hammer in place of a wrench.

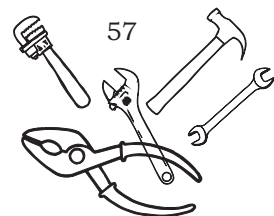

It is important for the plumber to wear the appropriate personal protective equipment (PPE) in order to protect oneself.

The personal protective equipment includes safety glasses or goggles, earplugs or earmuffs, protective gloves, overalls or other close fitting clothing. Safety shoes or boots with reinforced toe-caps will protect one's feet if any heavy or sharp items are dropped.

Falls

Many plumbing tasks are carried out at varied heights and depths. These include plumbing work on roofs, installing or repairing gutters and downpipes, accessing roof cavities through manholes, etc. Safe work methods must be established before a worker is required to access the task. The options for work at height (in their preferred order) are as follows.

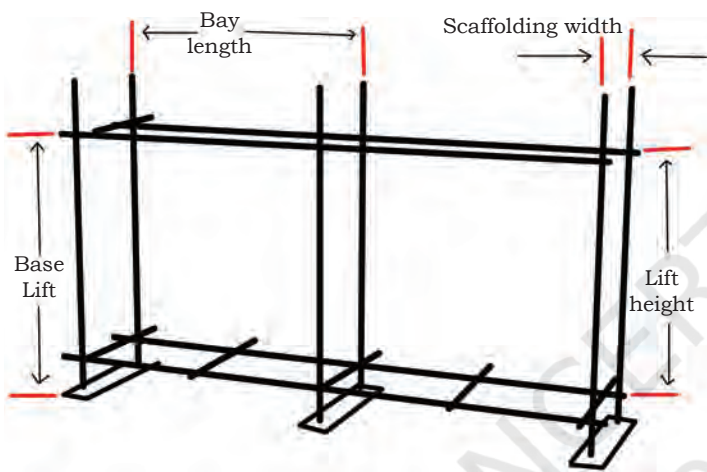
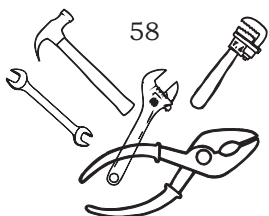

Fig. 6.3: Fall

1. Use fall protection devices (such as temporary work platforms or scaffolding)
2. Use a work positioning system (such as a rope access system to position and support the worker for the duration of the task)
3. Use a fall injury prevention system (such as an industrial safety net or a safety harness)
4. Use a ladder, as long as it can be employed safely for the duration of the task. This will require procedures and training for the workers who will use it.

Protection from falls

Each year, falls consistently account for the greatest number of fatalities in the construction industry. A number of factors are often involved in falls, including unstable working surfaces, misuse or failure to use fall protection equipment and human error. Using guardrails, fall arrest systems, safety nets, covers and



restraint systems can prevent many deaths and injuries from falls.

Precautions

- (i) Aerial lifts or elevated platforms should be considered to provide safer elevated working surfaces
- (ii) Erect guardrail systems with toe boards and warning lines or install control line systems to protect workers near the edges of floors and roofs
- (iii) Cover floor holes; and/or use safety net systems or personal fall arrest systems

Ladders

Ladders and stairways are another source of injuries and fatalities among construction workers. Injuries could occur due to bad quality ladder, loose ladder and narrow or steep, slippery stairways.

Precautions

- (i) Use a ladder which is strong for the task.
- (ii) Make sure that ladders are long enough to safely reach the work area.
- (iii) Mark or tag ('Do Not Use') damaged or defective ladders for repair or replacement, or destroy them immediately.
- (iv) Never load ladders beyond the maximum intended load or beyond the manufacturer's rated capacity.
- (v) Ensure that the load rating can support the weight of the user, including materials and tools.
- (vi) Avoid using ladders with metallic components near electrical work and overhead power lines.

Stairways

Slips, trips and falls on stairways are a major source of injuries and fatalities among the construction workers.

Precautions

- (i) Stairway treads and walkways must be free of dangerous objects, debris and materials.
- (ii) Slippery conditions on stairways and walkways must be corrected immediately.



(a)



(b)

Fig. 6.4 (a) Acid injury on hands, (b) Fire hazard

- (iii) Make sure that treads cover the entire step and landing. The treads should be made enough wide so that there is no slipping. Stairways having four or more risers or rising more than 30 inches must have at least one handrail.

Manual Handling

A plumber's work often involves significant manual handling hazards. Handling heavy objects and moving them, often in uncomfortable postures because of lack of space to move freely, creates a risk of traumatic injury, such as a strained back. The need for continuous repetitive movements can lead to injuries due to exertion, affecting the neck, back, hand and arms over a period of time. Work should be arranged and monitored to minimise the risk of overuse injuries.

Hazardous Substances

Hazardous substances are chemicals used to carry out work, or present in the work environment. All of these may create hazards for plumbers if their use in the workplace is not managed with care. These hazardous substances may be Oxy-acetylene, Fluxes (solder), Lead, Hydrochloric acid, Degreasers and solvents, Adhesives or Caulking compounds.

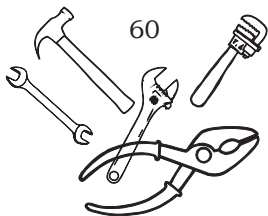

Fig. 6.5: Inhalation hazard sign

Biological Hazards

Health effects of exposure to sewage include tetanus (caused by a toxin produced by a bacteria common in soil and sewage), leptospirosis (caused by a parasitic worm), hepatitis A, and parasites, such as giardia and cryptosporium. The degree of harm that can result depends on the microbes present, and the extent and duration of exposure. Microbes in raw sewage can enter the body through the nose or mouth, particularly if a person drinks contaminated water or by hand-to-mouth transmission.

1. Assume anything touched by sewage as contaminated.
2. Do not eat or drink in any sewage handling area.
3. Wash hands well with soap and clean water, preferably hot, before eating or drinking, and



after touching any surface or object that may be contaminated by sewage.

4. Immediately wash and disinfect any wound that comes in contact with sewage.
5. Change out of work clothes before leaving the work site (soiled work clothes should be bagged and laundered separately from other clothing).
6. Wear appropriate protection. This includes rubber boots and gloves, overalls and eye protection (wear goggles if a hose is being used, as safety glasses will not protect against splashing).

Electricity

Electric leads must be kept away from water. Because plumbers use powered tools in proximity to water supply in all weather conditions, there is always the possibility of electrocution if work practices do not take into account the presence of electrical hazard. Insulated hot water pipes with 240-volt heat trace cables are used to maintain water temperature in many modern apartments. If power to the heat trace cable is not isolated, there is potential for electrocution when a plumber unknowingly cuts through the insulated pipe. Simply turning off the water supply valve will not shut down the power to the cable but the power supply should also be shut down.



Fig. 6.6: Electric plug



Fig. 6.7: Burn on hand

Burns

Hot water services store water at high temperatures. Maintenance and repair work must be carried out carefully to avoid scalds and steam burns. The unexpected release of hot water or steam could result in serious injury and permanent disfigurement.

Trenches and Confined Spaces

Plumbers working in trenches, pits, tanks, beneath houses and in roof cavities must understand and plan for the significant hazards in confined spaces. In sewage systems, the release of toxic gases can cause the plumber to collapse, become unconscious and die. Before any



Fig. 6.8: Hazardous Toxic Gas

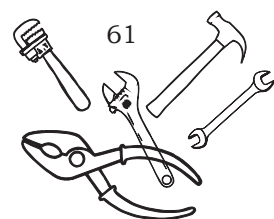

worker begins a job in a confined space (such as a pit or tunnel) where hazardous gases could be present or oxygen may be deficient, there must be a full assessment of the worksite and the safeguards required.

Trenching

Trench collapses cause dozens of fatalities and hundreds of injuries each year.

Precautions

- (i) Never enter an unprotected trench.
- (ii) While entering a trench, proper support like ladder, ropes, oxygen cylinder, goggles, etc., should be provided to the worker at a certain interval of depth.
- (iii) Employ a registered professional engineer to design a protective system for trenches 20 feet deep or greater.
- (iv) Always provide a way to exit a trench, such as a ladder, stairway or ramp—no more than 25 feet of lateral travel for employees in the trench.
- (v) Keep soil at least two feet behind the edge of a trench.
- (vi) Make sure that trenches are inspected by site engineer prior to entry and after any hazard-increasing event, such as a rainstorm, vibrations or excessive surcharge loads.



Fig. 6.9: Blisters due to Sunburn

Sunburn and Heat Stress

Workers who are exposed to extreme heat or work in hot environments may be at risk of heat stress. Heat stress can result in heat stroke, heat exhaustion, heat cramps, or heat rashes. Heat stress, sunburn and skin cancer can all result from prolonged exposure to ultraviolet radiation from the sun. The longer the skin is exposed, the greater the risk, regardless of tan or skin pigment.

Scaffolding

A scaffold is a temporary structure made of bamboo or iron pipe to support workers to carry out the work. When scaffolds are not erected or used properly, fall hazards can occur.

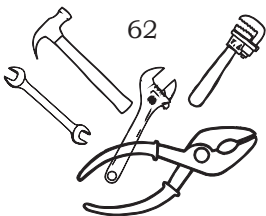

Precautions

- (i) Scaffold must be sound, rigid and sufficient to carry its own weight, plus four times the maximum intended load without settling or displacement. It must be erected on solid footing.
- (ii) Unstable objects, such as barrels, boxes, loose bricks or concrete blocks must not be used to support scaffolds or planks.
- (iii) The scaffold must not be erected, moved, dismantled or altered except under the supervision of person who supplies, installs and dismantles the scaffolding.
- (iv) The scaffold must be equipped with guardrails, mid rails and toe boards.
- (v) Scaffold accessories, such as braces, brackets, trusses, screw legs or ladders that are damaged or weakened must be immediately repaired or replaced.
- (vi) Scaffold platforms must be tightly planked with scaffold plank grade material or equivalent. A plank is timber that is flat, elongated and rectangular with parallel faces that are high and long.
- (vii) Synthetic and natural rope is used in suspension scaffolding, that is a hanging-type scaffolding. It must be protected from heat-producing sources.
- (viii) The scaffold can be accessed by using ladders and stairwells.
- (ix) The scaffolds must be at least 10 feet from electric power lines at all times.

Safety Check

For quality control of any work, a checklist for safety is prepared. A checklist is a list of items you need to verify, check or inspect. Checklists are used in every imaginable field—from building inspections to complex medical surgeries. Using a checklist allows you to ensure that you do not forget any important steps. These checklists are prepared for office work, construction site, handling of equipment, etc. These checklists are available with the user and agencies. This checklist should be followed

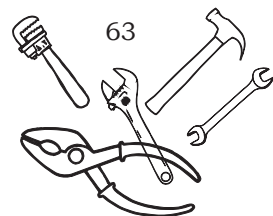

in routine practice to maintain standard and quality. Adoption of these checklists will reduce accidents and hazards.

Precautions at Workplaces

For safe operation, following precautions should be ensured at the workplace.

- (a) Precautions must be taken against a person falling from a working platform erected at various heights in a building.
- (b) Protection against structural collapse (while work is taking place) i.e., the building falling down.
- (c) Safeguards to be used when a person is working in excavations like well or mines.
- (d) Care should be taken to prevent drowning (falling into water).
- (e) Steps should be made for safe traffic routes (on sites) to avoid accidents.
- (f) Prevention and control of emergencies services (site emergency evacuation procedures, etc.).
- (g) Provision of welfare facilities—washroom, washing facilities, canteens/rest areas, shower facilities, (if required).
- (h) Provision of site-wide issues—clean and tidy sites, adequate lighting, constant and fresh air supply, etc.
- (i) Training, inspection and reports—training of staff, use of trained staff to do the work, supervision of staff and monitoring the work carried out to ensure it is carried out in a safe manner.

Reporting of Injuries, Diseases and Danger

For better working conditions in a factory or industry, it is necessary to record and report the injuries, diseases and danger that occur to a worker or employee. Special care should be taken to avoid dangerous occurrences like collapse of building, excavation, etc. It is always advisable to maintain an accident book document, where detail of all accidents is recorded, no matter how minor. Moreover following points should be also checked.

1. Maintain a Material Safety Data Sheet (MSDS) for each chemical in the facility. Make this

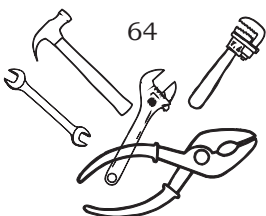

information accessible to employees at all times in a language or format that is clearly understood by all personnel.

2. Train employees on how to read and use the MSDS.
3. Follow the manufacturer's MSDS instructions for handling hazardous chemicals.
4. Train employees about the risks of each hazardous chemical being used.
5. Provide spill clean-up kits in areas where chemicals are stored.
6. Have a written spill control plan.
7. Train employees to clean up spills, protect themselves and properly dispose of used materials.
8. Provide proper personal protective equipment and enforce its use.
9. Store chemicals safely and securely.

Signs and Symbols on Site

Sign and symbols are used to inform and alert the people on all aspects. Some common safety symbols are discussed here.

- Circular red borders along with a cross bar and black symbols on a white background indicates what must not be done like 'No Smoking'
- White symbol on blue background indicates what must be done like 'Wear Eye Protection'
- Triangular yellow background with a black border and symbol inside warns of hazard or danger, for example, 'Danger Electric Shock Risk'
- Square or rectangular white symbols on a green background indicates or gives information on safety provision like 'First Aid Facilities'.

Personal Protective Equipment at Work (PPE)

It is defined as any equipment (including clothing affording protection against the weather), which is intended to be worn or held by a person at work, and which protects them against one or more risks to their health.



Fig. 6.10: Safety symbols

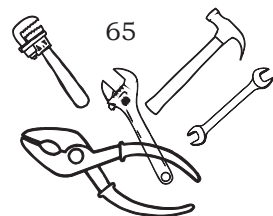

Safety Equipment



Fig. 6.11: Eye protection



Fig. 6.12: Hand protection



Fig. 6.13: Head protection



Fig. 6.14: Boot

(a) Eye protection: It comes in the form of

- (i) Safety glasses—a typical application could be during lead welding
- (ii) Safety goggles—these provide a higher level of protection than safety glasses, as they fit closely to the face
- (iii) Welding goggles—these include specialist coloured lenses.

(b) Hand protection: It is usually used in plumbing and includes the following.

- (i) General-purpose gloves—these help protect against cutting or puncture, wounds; an example of their use could be lifting concrete blocks or lifting steel tube.
- (ii) Specialist gloves—these are typically used to deal with hazardous substances, such as dry ice used in pipe-freezing applications.
- (iii) Rubber gloves—these help protect against contact with waste systems and sanitary appliances. Gloves also provide protection against a disease known as dermatitis, which is caused by the hands coming in contact with materials classified as irritants.

(c) Head Protection: Such injuries occur when we are not prepared to protect our head. Serious head injuries can get fatal.

It is a mandatory requirement to wear a safety helmet when working on construction sites of multistorey buildings or commercial housing, industrial building construction etc. In addition, a safety helmet needs to be worn while working at heights or in a trench.

A safety helmet must

- (i) be properly adjusted to fit.
- (ii) be replaced if it becomes defective or damaged.

(d) Foot protection: It is necessary to protect foot from injuries caused during plumbing installation work. It is necessary for workers to wear the standard safety boots.

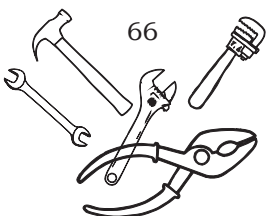

(e) Ear protection: It is used while working in noisy areas or with equipment that generate high levels of noise. Ear protection gear includes:

- (i) Ear defenders
- (ii) Ear plugs

(f) Respiratory protection: When there is dust at workplace, the efficiency of workers gets affected, hence, it is necessary to use respiratory protection system. Some important respiratory equipment are.

- (i) Simple dust mask—this mask is used against normal pollution dust, etc.
- (ii) Cartridge-type respirator—these masks can guard against a range of substances, such as high levels of dust or fumes; different disposable cartridges are required to protect against different types of substances.
- (iii) Full breathing apparatus—usually used in specialist work in confined spaces, such as drains or sewers.



Fig. 6.15: Respiratory protection

Fire

Fire is classified into groups according to the type of fuel

- (i) Class A—fires involving solid materials, extinguished by water
- (ii) Class B—fires involving flammable liquids, extinguished by foam or carbon dioxide
- (iii) Class C—fires involving flammable gases, extinguished by dry powder
- (iv) Class D—fires involving flammable metals, extinguished by dry powder

Fire-fighting Equipment

There is a variety of different types of fire fighting equipment. In undertaking plumbing work you are more likely to come across the fire extinguisher as the main source of protection; following are the steps to use a fire extinguisher.

- (i) An extinguisher should be kept in the immediate work area when not working
- (ii) A fire extinguisher should only be used when it is safe to do so. Personal safety must come before attempts to contain a fire

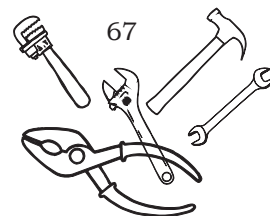

- (iii) Fire extinguishers should only be used by those trained in their use
- (iv) The following table shows the colour coding for extinguishers for dealing with the different types of fire.

Type of extinguisher	Colour code	Main use
Water	Red	Wood paper or fabrics
Foam	Cream	Petrol oil, fats and paints
Carbon oxide	Black	Electrical equipment
Dry powder	Blue	Liquids, gases, electrical equipments

Emergency Services and First Aid

During an emergency period, the following actions should be taken

- (i) Find a telephone in a safe environment, well away from the emergency
- (ii) Dial the emergency service number—Fire 102, Police 100, Ambulance 101

Summoning the Emergency Services

- (a) Minimise the time taken for the emergency services to reach you
- (b) Minimise the risk to operators, if there is an emergency
- (c) Include environmental and other emergencies in your plan



Fig. 6.16: First Aid box

- (d) Employers and the self-employed need to assess the first aid requirements of their work
- (e) Make sure there are enough trained first aiders and facilities to help casualties of illness or injury immediately, and that an ambulance or other professional help can be summoned without delay.

First Aid: It is necessary to have the following items in a first aid kit. These

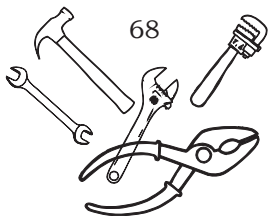

items help provide the patient immediate relief from pain or injury.

- (a) Plasters
- (b) Sterile dressings
- (c) Triangular bandage
- (d) Safety pins(sling)
- (e) Disposable gloves
- (f) Crepe bandages
- (g) Scissors, tweezers
- (h) Cotton wool tap/faucet
- (i) Alcohol-free antiseptic wipes
- (j) Sterile pads

First aid assessment should take into account:

- (a) The nature of the work
- (b) The history and consequences of injuries
- (c) The nature and distribution of the workforce
- (d) The remoteness of the site from the emergency services, including location, terrain and weather conditions
- (e) Working on shared or multi-occupied sites
- (f) Holidays and other absences of first aiders
- (g) The presence of trainees and the public
- (h) The possibility of medical conditions or allergies

Safety Guidelines

Step 1 – Identify potential causes of workplace injury and illness

- (i) Does the nature of the work being carried out pose a hazard to people's health and safety?
- (ii) Have these hazards been identified in work that is being carried out?
- (iii) Has incident and injury data been reviewed?
- (iv) Has consultation with workers and their health and safety representatives occurred?
- (v) Is specialist or external assistance required?

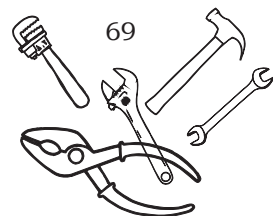

Step 2 – Assess the risk of workplace injury and illness

- (i) How often does a hazard have the potential to cause harm?
- (ii) What type of injuries would the hazard cause?
- (iii) How serious are the injuries?
- (iv) Does the number and composition of workers and other people affect how first aid should be provided?
- (v) Could the size and location of the workplace affect how first aid is provided?

Step 3 – What first aid is required?

(a) First aiders

- (i) How many first aid helpers are needed?
- (ii) What competencies do they require?
- (iii) What training do they need?

(b) First aid kits and procedures

- (i) What kits or modules are needed and where should they be located?
- (ii) Is other first aid equipment needed?
- (iii) Who is responsible for maintaining the kits?
- (iv) What procedures are needed for my workplace?

(c) First aid facilities

- (i) Is a first aid room or health centre required?

Practical Exercises

Activity 1

Visit to Fire Station

Material required

- 1. Copy
- 2. Pencil

Procedure

- 1. Fix an appointment with the Fire Station for a visit.
- 2. Reach the station as per schedule.
- 3. Discuss about all the safety tools, gadget and machines.
- 4. Do the handling and operating practice under the supervisor of fire station and teacher.

Activity 2

Drawing first aid equipment

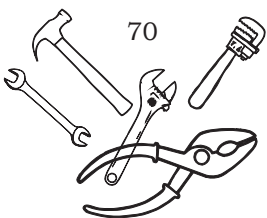

Material required

1. First aid equipment
2. Tools
3. Drawing copy
4. Pencil
5. Rubber

Procedure

1. Select the fire safety equipment to be drawn.
2. Open the components with tools.
3. Draw the images of first aid equipment.

Activity 3

Draw the symbols and signs of safety at site

Material required

1. Pencil
2. Paper
3. Drawing sheet
4. Poster

Procedure

1. Identify the symbols and signs.
2. Draw the images.
3. Also write the uses of these symbols.
4. Display these posters in the classroom.

Check Your Progress

A. Answer the following

1. Why is it important to comply with health and safety on site?
2. What general hygiene practices must be adhered at the workplace?
3. Why should the correct clothing, footwear and headgear be worn at all times?
4. Why is it important to maintain good personal hygiene?
5. What are the possible causes of fire in the working environment?
6. What preventive actions can be taken to minimise the risk of fire?
7. What organisational procedures should be followed in the event of a fire?
8. Why should a fire never be approached unless it is safe to do so?
9. What is the basic first aid that should be applied in the event of an accident?

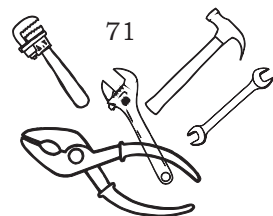

10. What action should be taken to ensure the safety of an injured and uninjured?
11. Why is it important to use the correct lifting techniques?
12. What are the employee's responsibilities in relation to health and safety regulations?

B. Multiple choice questions

1. Fall Hazard occurs when scaffoldings are erected _____.
(a) improperly (b) properly
(c) timely (d) None of these
2. Slips, trips and falls on stairways are a major source of injuries and fatalities among _____ workers.
(a) construction (b) retail
(c) automotive (d) None of these
3. Trench collapses cause dozens of fatalities and hundreds of injuries each _____.
(a) year (b) month
(c) time (d) None of these
4. Head can be protected by wearing the _____.
(a) helmet (b) safety cap
(c) gloves (d) None of these
5. Eye injuries can be prevented during work by wearing the _____.
(a) safety glass
(b) safety glass with side shield
(c) cap
(d) None of these

C. Fill in the blanks

1. Powered tools are used to _____ everyday tasks in the plumbing industry.
2. Hand tools can also be _____ if they are not used correctly.
3. Plumber work often involves significant _____ handling hazards.
4. Electric leads must be kept away from _____.
5. Heat stress, sunburn and skin cancer can all result from prolonged exposure to ultraviolet radiation from the _____.

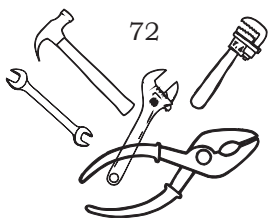

Glossary

Guarded system: prevents the operator from having any part of their body in the danger zone during the operating cycle.

Landing: is the area of a floor near the top or bottom step of a stair. An intermediate landing is a small platform that is built as part of the stair between main floor levels and is typically used to allow stairs to change directions, or to allow the user a rest.

Risers: a vertical section between the treads of a staircase.

Scald: injury caused due to hot liquid or steam.

Shoring: is the construction of a temporary structure to support a temporarily unsafe structure. These support walls laterally.

Steps: stairs and steps share a single meaning. Both refer to a series of steps—those ‘structures consisting of a riser and a tread.’

Toe board: is a long piece of wood nailed horizontally along a roof in various places. The purpose of a toe board is to safeguard tools, equipment and objects that fall from the edge or is being pushed down from the structure.

Tread: a stair tread is the horizontal portion of a set of stairs on which a person walks.

Trench: a long, narrow ditch.

© NCERT
not to be republished

Answer Key

Units	Multiple choice questions	Fill in the blanks false
-------	---------------------------	--------------------------

Unit 1: Pipes — Cutting, Threading, Joining and Testing of Pipelines

- | | |
|------|--------------------|
| 1. a | 1. bottom |
| 2. b | 2. pressure |
| 3. d | 3. thread per inch |
| 4. b | 4. 1/2, 2/3 |

Unit 2: Plumbing and Sanitary Fixtures

- | | |
|------|----------------|
| 1. c | 1. bowl shaped |
| 2. a | 2. legs |
| 3. a | 3. toilets |
| 4. a | 4. water |
| | 5. heating |

Unit 3: Basic Building Construction

- | | |
|------|---------|
| 1. c | water |
| 2. e | hole |
| 3. d | grooves |
| 4. d | fasten |
| 5. d | |

Unit 4: Pumps and their Installation

- | | |
|------|----------------------|
| 1. d | 1. Mechanical action |
| 2. c | 2. 25 |
| 3. a | 3. building |
| 4. d | 4. water |
| 5. a | 5. water meter |

Unit 5: Performing various Plumbing related Operations and Procedures

1. vitreous China
2. nominal
3. tap or faucet
4. main supply lines of water supply system and pipelines

Unit 6: Maintaining a Healthy, Safe and Secure Work Environment

- | | |
|------|--------------|
| 1. a | 1. carry out |
| 2. a | 2. dangerous |
| 3. a | 3. manual |
| 4. b | 4. water |
| 5. a | 5. sun |

4. Head can be protected by wearing the _____.
- (a) helmet (b) safety cap
(c) gloves (d) None of these
5. Eye injuries can be prevented during work by wearing the _____.
- (a) safety glass
(b) safety glass with side shield
(c) cap
(d) None of these

C. Fill in the blanks

1. Powered tools are used to _____ everyday tasks in the plumbing industry.
2. Hand tools can also be _____ if they are not used correctly.
3. Plumber work often involves significant _____ handling hazards.
4. Electric leads must be kept away from _____.
5. Heat stress, sunburn and skin cancer can all result from prolonged exposure to ultraviolet radiation from the _____.

Glossary

Guarded system: prevents the operator from having any part of their body in the danger zone during the operating cycle.

Landing: is the area of a floor near the top or bottom step of a stair. An intermediate landing is a small platform that is built as part of the stair between main floor levels and is typically used to allow stairs to change directions, or to allow the user a rest.

Risers: a vertical section between the treads of a staircase.

Scald: injury caused due to hot liquid or steam.

Shoring: is the construction of a temporary structure to support a temporarily unsafe structure. These support walls laterally.

Steps: stairs and steps share a single meaning. Both refer to a series of steps—those 'structures consisting of a riser and a tread.'

Toe board: is a long piece of wood nailed horizontally along a roof in various places. The purpose of a toe board is to safeguard tools, equipment and objects that fall from the edge or is being pushed down from the structure.

Tread: a stair tread is the horizontal portion of a set of stairs on which a person walks.

Trench: a long, narrow ditch.

© NCERT
not to be republished

Answer Key

Units	Multiple choice questions	Fill in the blanks false
-------	---------------------------	-----------------------------

Unit 1: Pipes — Cutting, Threading, Joining and Testing of Pipelines

- | | |
|------|--------------------|
| 1. a | 1. bottom |
| 2. b | 2. pressure |
| 3. d | 3. thread per inch |
| 4. b | 4. 1/2, 2/3 |

Unit 2: Plumbing and Sanitary Fixtures

- | | |
|------|----------------|
| 1. c | 1. bowl shaped |
| 2. a | 2. legs |
| 3. a | 3. toilets |
| 4. a | 4. water |
| | 5. heating |

Unit 3: Basic Building Construction

- | | |
|------|---------|
| 1. c | water |
| 2. e | hole |
| 3. d | grooves |
| 4. d | fasten |
| 5. d | |

Unit 4: Pumps and their Installation

- | | |
|------|----------------------|
| 1. d | 1. Mechanical action |
| 2. c | 2. 25 |
| 3. a | 3. building |
| 4. d | 4. water |
| 5. a | 5. water meter |

Unit 5: Performing various Plumbing related Operations and Procedures

1. vitreous China
2. nominal
3. tap or faucet
4. main supply lines of water supply system and pipelines

Unit 6: Maintaining a Healthy, Safe and Secure Work Environment

- | | |
|------|--------------|
| 1. a | 1. carry out |
| 2. a | 2. dangerous |
| 3. a | 3. manual |
| 4. b | 4. water |
| 5. a | 5. sun |